



Parts Manual

Proportional Valves PVG 32



Revision View

Date	Page	Changed	Revision
Oct 2004	all	New lay out (520L0211)	B
Dec 2007	all	Major revision	CA
Apr 2008	all	Major revision	11006794
Oct 2008	12, 15	UDC - UDC2 changed	AC
Apr 2009		PVHC added	AD
Sep 2009	14, 15	Pin numbers	AE
Jan 2010	68	Japan location changed	BA
Feb 2010	various	Handle on drawing	BB
May 2014	All	Danfoss layout	CA
Aug 2014	66	PVAS description changed	CB
Nov 2014	61, 63, 65, 66	O-ring added	CC
Feb 2015	9, 54	Torque changed	CD
Feb 2015	61, 63, 65		CE

Survey

Sectional Drawing	4
Identification and Installation	5
Pos. 1: PVP, pump side module.....	30
Pos. 1: PVPV/M, pump side module.....	38
Pos. 2: PVB, basic module.....	40
Pos. 3: PVLA, anti-cavitation valve.....	40
Pos. 4: PVLV, shock and anti-cavitation valve	40
Pos. 5: PVS/PVSI, end plate	44
Pos. 6: PVAS, assembly kit, PVP	46
Pos. 6: PVAS, assembly kit, PVPV/M	48
Pos. 7: PVPX, LS unloading valve.....	50
Pos. 8: PVPC, plug for external pilot oil supply	50
Pos. 9: PVBS, main spool.....	52
Pos. 10: PVM, mechanical activation.....	54
Pos. 11: PVMD, cover for mechanical activation	56
Pos. 12: PVH, cover for hydraulic activation	56
Electrical actuation with AMP connector	58
Electrical actuation with Hirschmann connector	60
Electrical actuation with Deutsch connector.....	62
Set of seals for PVG 32	64

Rated Pressure

Product	Rated Pressure
PVG 32 w. PVS	300 bar [4351 psi]
PVG 32 w. PVSI	350 bar [5076 psi]
PVG 32 w. PVBZ	210 bar [3046 psi]
PVG 32 w. HIC steel	350 bar [5076 psi]
PVG 32 w. HIC aluminium	210 bar [3046 psi]
PVG 120/32 w. PVS	300 bar [4351 psi]
PVG 120/32 w. PVSI	350 bar [5076 psi]
PVG 100/32 w. PVS	300 bar [4351 psi]
PVG 100/32 w. PVSI	350 bar [5076 psi]

Survey

It's up to the customer to decide on the required degree of safety for the system.

Safety

All marks and all types of directional control valves – inclusive proportional valves – can fail and cause serious damage. It is therefore important to analyze all aspects of the application. Because the proportional valves are used in many different operation conditions and applications, the manufacturer of the application is alone responsible for making the final selection of the products – and assuring that all performance, safety and warning requirements of the application are met.

Survey

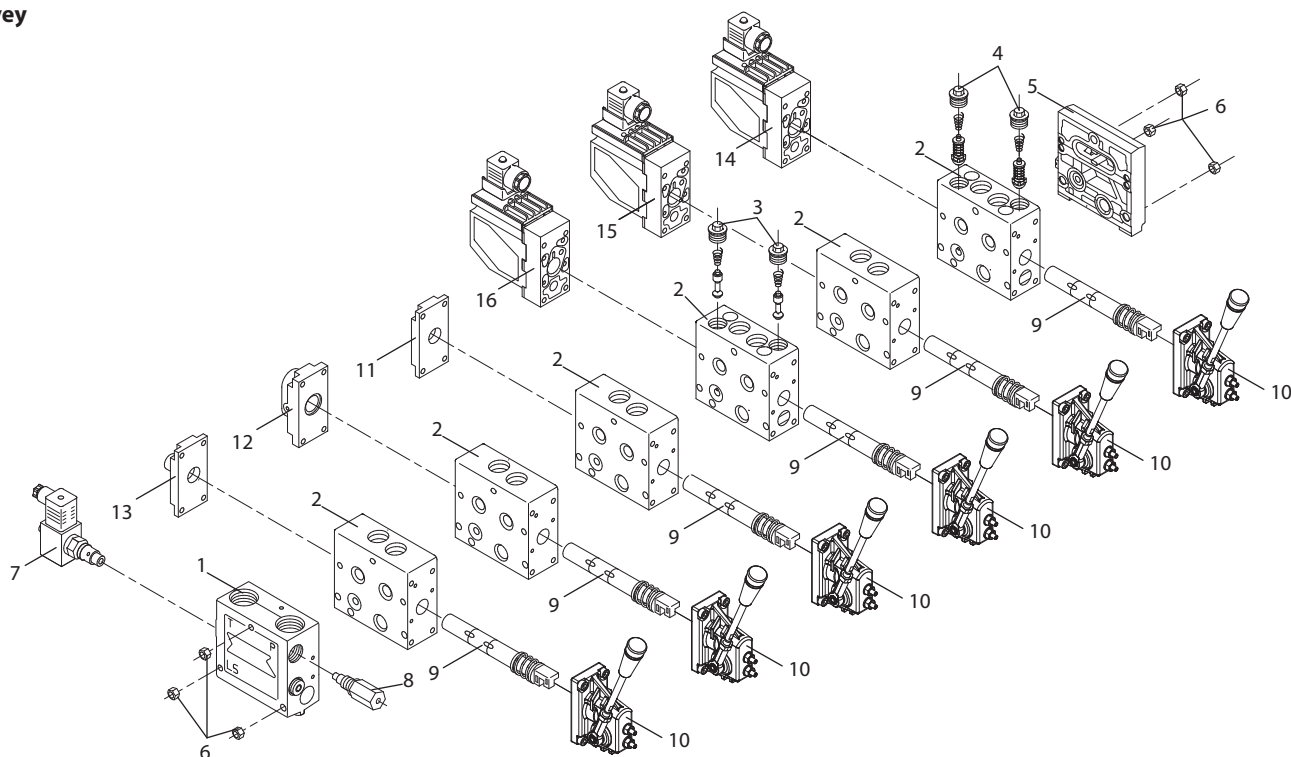

V310151.A

A mix of electrical actuation and hydraulic actuation on the same valve stack is not safe. PVE and PVH are designed for different pilot pressure.

Cost-Free Repairs

We would point out that cost-free repairs as mentioned in Danfoss General Conditions of Sale, are carried out only at Danfoss or at service shops authorized by Danfoss.

Sectional Drawing

PVG 32
Sectional Drawing

- | | |
|--|--|
| 1. Pressure relief valve | 12. LS-pressure relief valve |
| 2. Pressure reduction valve for pilot supply | 13. Shock and suction valve, PVL |
| 3. Pressure gauge connection | 14. Pressure compensator |
| 4. Plug, open center | 15. LS-connection, port A |
| 5. Orifice, closed center | 16. LS-connection, port B |
| 6. Pressure adjustment spool | 17. Anti cavitation valve, PVLA |
| 7. Plug, closed center | 18. Load drop check valve |
| 8. LS-connection | 19. Pilot supply for PVE |
| 9. LS-signal | 20. Max. oil flow adjustment screws for port A and B |
| 10. Shuttle valve | |
| 11. Main spool | |

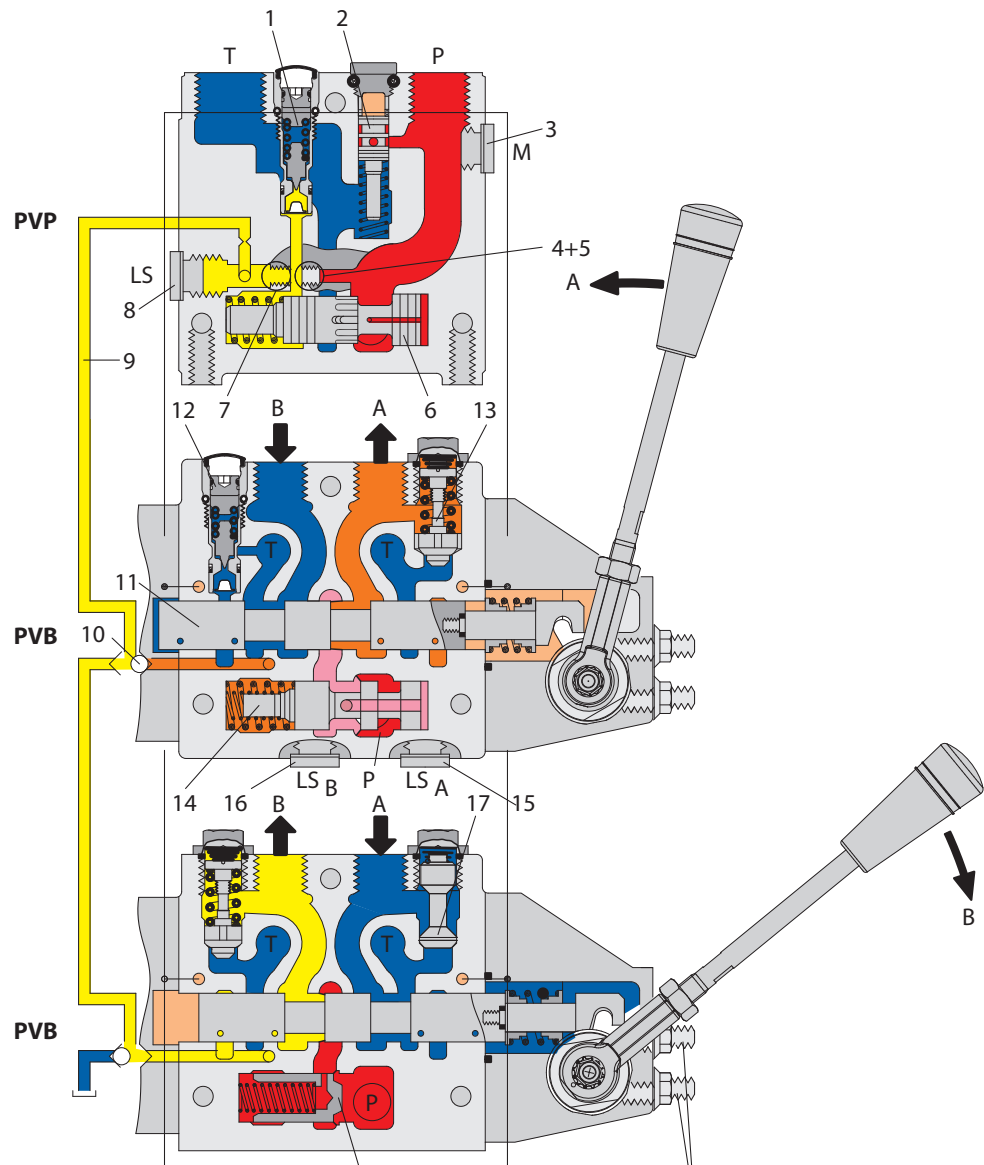

Identification

Standard
Installation:
PVM on A-port Side

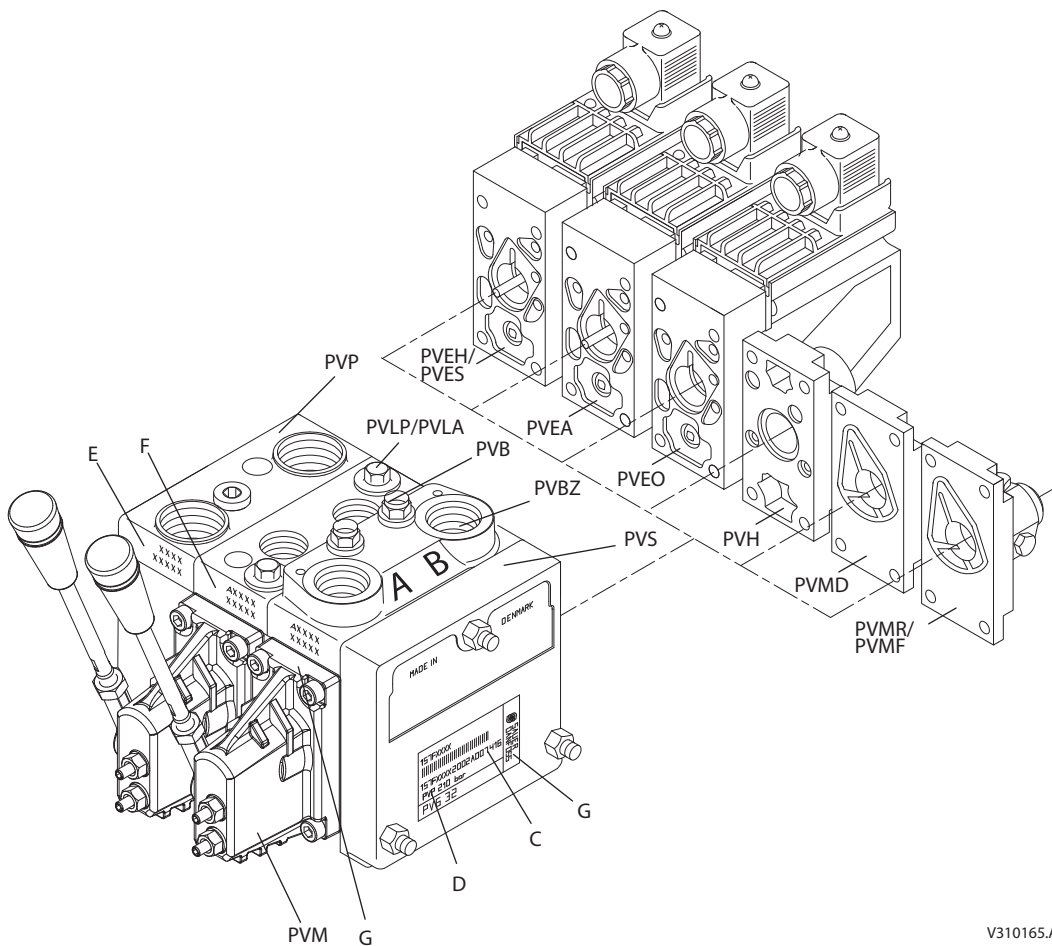
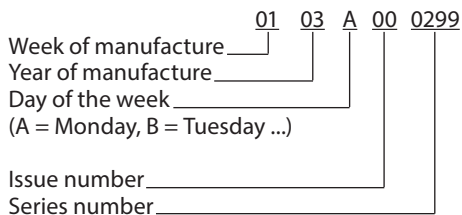

V310165.A

Identification Label

- C: PVG code number, week and year of manufacture
- D: PVG rated pressure
- E: PVP code number, week, year and day of manufacture, issue and series No.
- F: PVB code number, week, year and day of manufacture, issue and series No.
- G: PVM, week and year
- H: Identification label

A mix of electrical actuation and hydraulic actuation on the same valve stack is not safe. PVE and PVH are designed for different pilot pressure.

Installation

Installation

Modul of PVB	1	2	3	4	5	6	7	8	9	10	11	12
L mm	82	130	178	226	274	322	370	418	466	514	562	610
L [in]	[3.23]	[5.12]	[7.01]	[8.90]	[10.79]	[12.68]	[14.57]	[16.46]	[18.35]	[20.24]	[22.13]	[24.0]

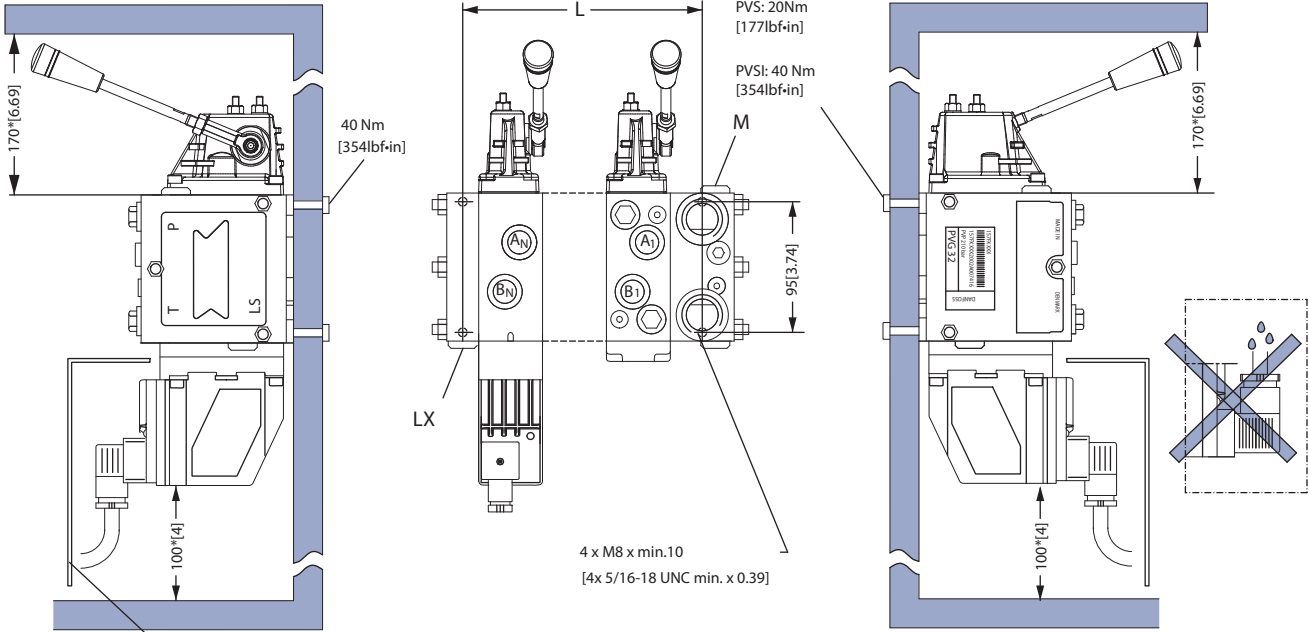

In particularly exposed applications, protection in the form of screening of the electrical actuator is recommended

V310139.A

Installation Priority Module,
PVSP

Installation

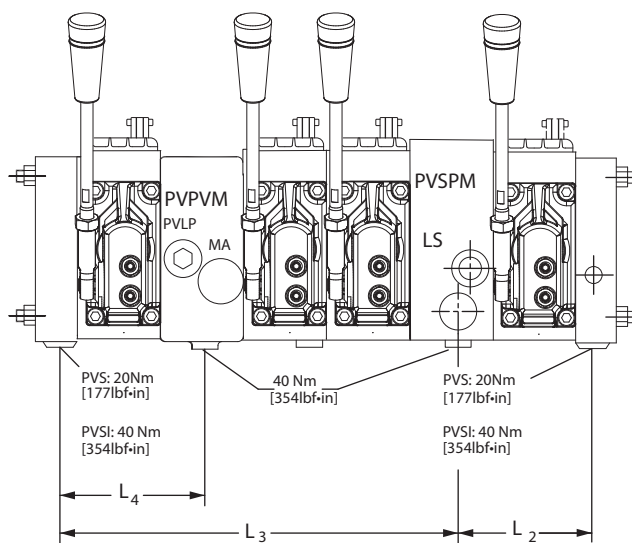

V310120.A

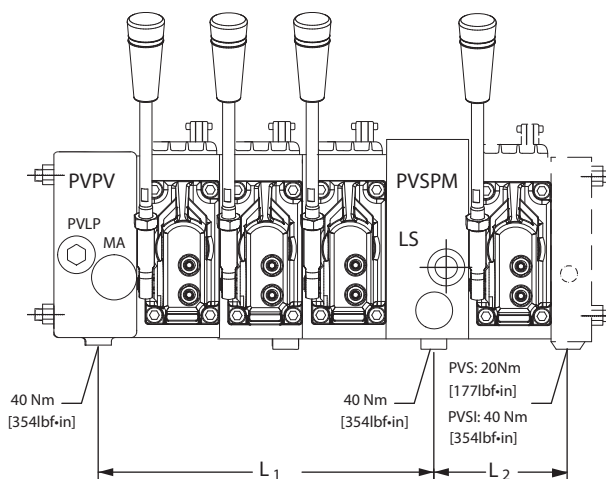

V310122.A

Metric (mounting thread M8 × min. 10) mm
SAE [mounting thread 5/16 - 18 UNC × min. 0.39 in]

PVB	0	1	2	3	4	5	6	7	8	9	10	11	12
L1 mm	47	95	143	191	239	287	335	383	431	479	527	575	623
[L1 in]	[1.85]	[3.74]	[5.63]	[7.52]	[9.41]	[11.30]	[13.19]	[15.08]	[16.97]	[18.86]	[20.75]	[22.64]	[24.53]
L2 mm	35	83	131	179	227	275	323	371	419	467	515	563	611
[L2 in]	[1.37]	[3.27]	[5.16]	[7.05]	[8.94]	[10.83]	[12.72]	[14.61]	[16.50]	[18.38]	[20.28]	[22.17]	[24.06]
L3 mm	-	131	179	227	275	323	371	419	467	515	563	611	659
[L3 in]	-	[5.16]	[7.05]	[8.94]	[10.82]	[12.72]	[14.61]	[16.50]	[18.38]	[18.39]	[22.17]	[24.06]	[25.94]
L4 mm	-	83	131	179	227	275	323	371	419	467	515	563	611
[L4 in]	-	[3.27]	[5.16]	[7.05]	[8.94]	[10.83]	[12.72]	[14.61]	[16.50]	[18.39]	[20.28]	[22.17]	[24.06]

Installation PVSX

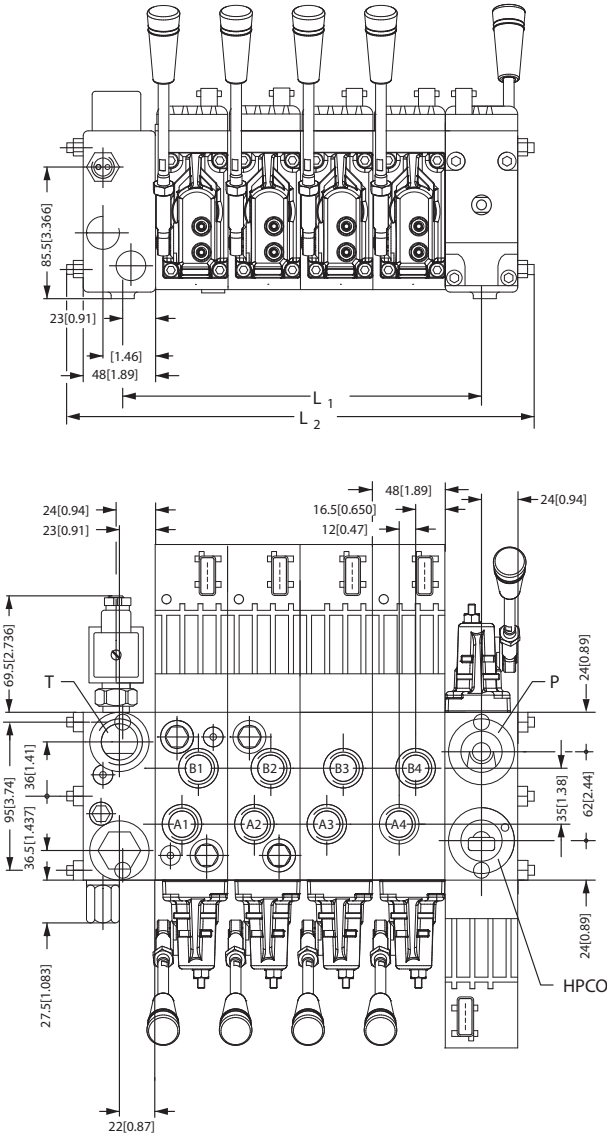

V310126.A

PVB	1	2	3	4	5	6	7	8	9	10	11	12
L1 mm	95	143	191	239	287	335	383	431	479	528	577	626
[L1 in]	[3.74]	[5.63]	[7.52]	[9.41]	[11.30]	[13.19]	[15.08]	[16.97]	[18.86]	[20.79]	[22.72]	[24.65]
L2 mm	165	213	262	311	360	409	458	507	551	600	649	698
[L2 in]	[6.50]	[8.39]	[10.31]	[12.24]	[14.17]	[16.10]	[18.03]	[19.96]	[21.69]	[23.62]	[25.55]	[27.48]

Installation

Standard installation,
PVM on A-port Side

Oil flow direction and setting of max. flow. PVM on A-port side.

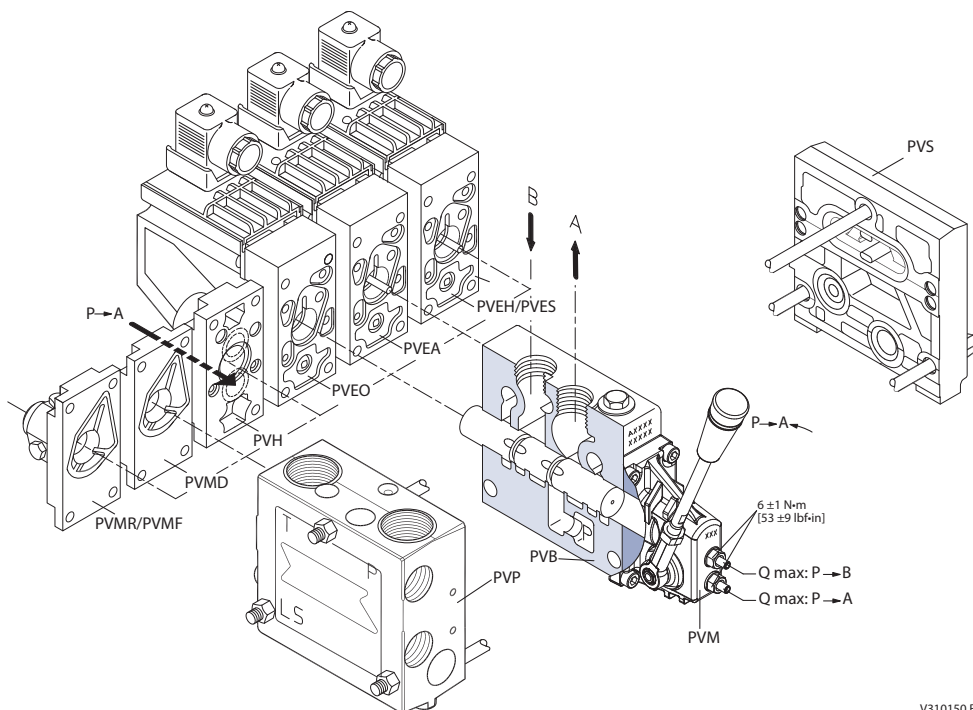

V310150.B

Option installation,
PVM on B-port Side

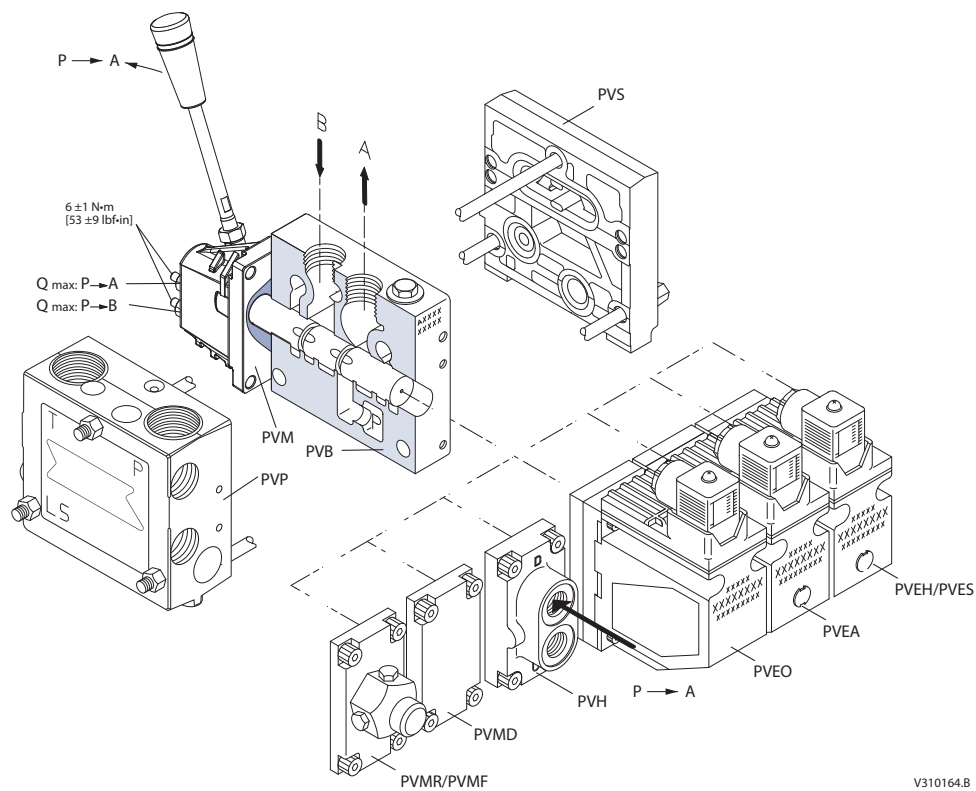

V310164.B

Installation

Standard and Option Installation

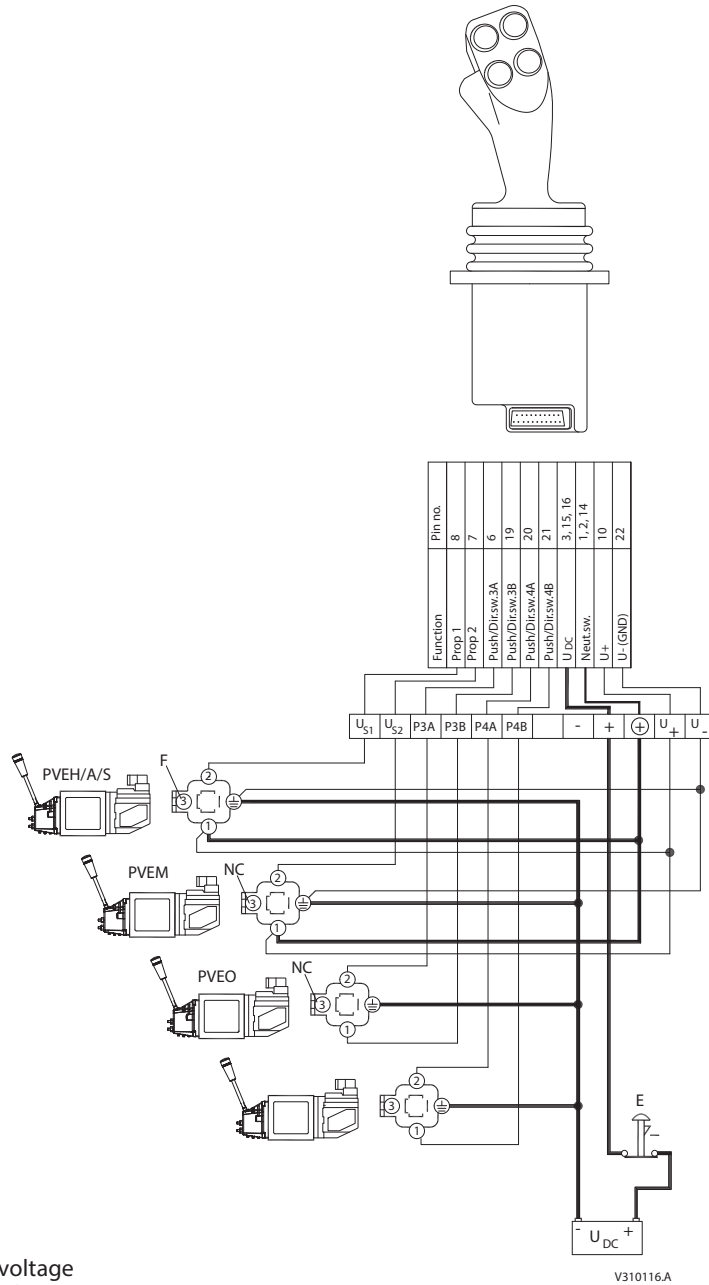

U_{DC} = Supply voltage
 U_S = Signal voltage

- E: Emergency circuit breaker
- F: Branch circuit for fault indication
- NC: Not connected

25 Pin SUB-D connector
 with M3 screws (MIL-DTL-24308)

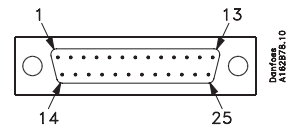

Notes

**Standard/Option
Installation AMP-Version**

**AMP-Version on/off
Standard***

Function	Signal voltage	
	pin 1	pin 2
Neutral	0	0
Q: P -> A	U_{DC}	0
Q: P -> B	0	U_{DC}

Option*

Signal voltage	
pin 1	pin 2
0	0
0	U_{DC}
U_{DC}	0

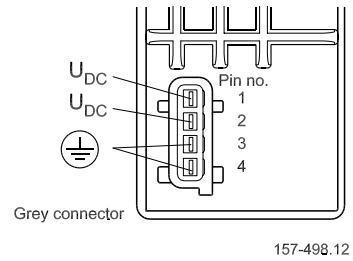

**AMP-Version
PVEO-DI**

On DI versions two U_{DC} connections (U_{DC} and U_{DC2}) are necessary.

- U_{DC} will supply the electronics
- U_{DC2} will supply the solenoid valves

The two ground pins (pin 3) are internally connected.

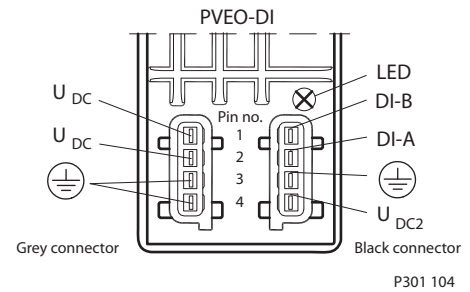

**AMP-Version
PVEA/PVEH/PVES
Standard***

Function	Signal voltage (U_s)
Neutral	U_s (pin 1) = $0.5 \cdot U_{DC}$
Q: P -> A	U_s (pin 1) = $(0.5 \rightarrow 0.25) \cdot U_{DC}$
Q: P -> B	U_s (pin 1) = $(0.5 \rightarrow 0.75) \cdot U_{DC}$

Option*

Signal voltage (U_s)
U_s (pin 1) = $0.5 \cdot U_{DC}$
U_s (pin 1) = $(0.5 \rightarrow 0.75) \cdot U_{DC}$
U_s (pin 1) = $(0.5 \rightarrow 0.25) \cdot U_{DC}$

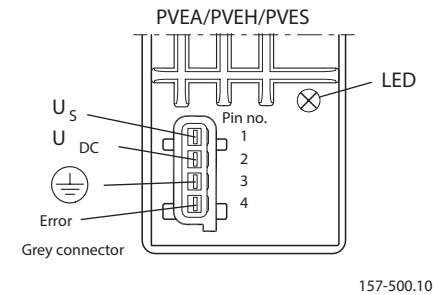

▲ WARNING

A shut off for pilot oil supply will not bring the spool to neutral on a PVEH (-DI/F/SP). To bring the PVB to neutral shut off power supply or give neutral set point.

**AMP-Version PVEA-DI /
PVEH-DI**

On DI versions two U_{DC} connections (U_{DC} and U_{DC2}) are necessary.

- U_{DC} will supply the electronics
- U_{DC2} will supply the solenoid valves

The two ground pins (pin 3) are internally connected.

* Standard installation: PVM on A-Port side
Option installation: PVM on B-Port side

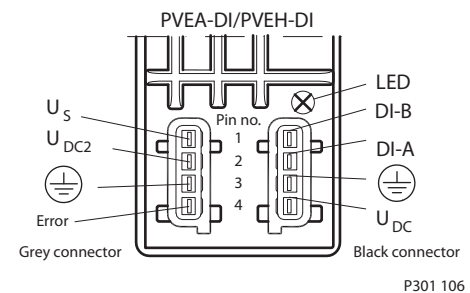

**Standard/Option
Installation AMP-Version**

**AMP-version PVEH-F
Standard**

Function	Signal voltage (U_s) (pin 1)	Float (pin 5)
Neutral	$0.5 \cdot U_{DC}$	0
Q: -> A	$(0.5 \rightarrow 0.25) \cdot U_{DC}$	0
Q: -> B	$(0.5 \rightarrow 0.75) \cdot U_{DC}$	0
Float	None or any voltage $\leq U_{DC}$	U_{DC}

Option*

Function	Signal voltage (U_s) (pin 1)	Float (pin 2)
Neutral	$0.5 \cdot U_{DC}$	0
Q: -> A	$(0.5 \rightarrow 0.75) \cdot U_{DC}$	0
Q: -> B	$(0.5 \rightarrow 0.25) \cdot U_{DC}$	0
Float	None or any voltage $\leq U_{DC}$	U_{DC}

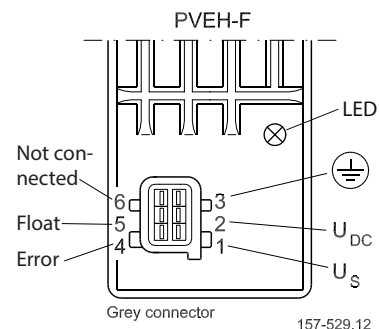

By option mounting the manual and the electrical actuation have to be interchanged as well as the spool has to be turned 180°.

AMP-version PVED-CC

V_{bat} : 11 - 32 V DC
CAN-L / CAN-H digital signal.
The pins are internally connected.
For control, see technical information
Electro hydraulic actuator type PDED-CC
(520L0665).

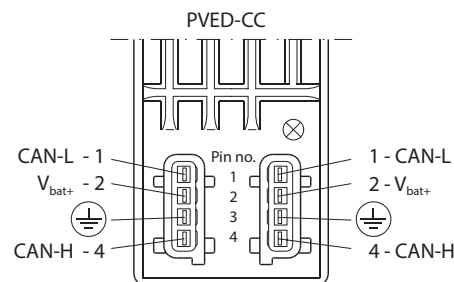

* Standard installation: PVM on A-Port side
Option installation: PVM on B-Port side

**Standard/Option
Installation
Hirschmann-Version**

**Hirschmann-Version on/off PVEO/PVEO-R
Standard**

Function	Signal voltage	
	pin 1	pin 2
Neutral	0	0
Q: P -> A	U_{DC}	0
Q: P -> B	0	U_{DC}

Option*

Signal voltage	
pin 1	pin 2
0	0
0	U_{DC}
U_{DC}	0

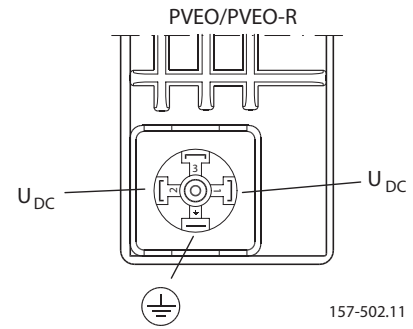

**Hirschmann-Version
proportional PVEH/PVES
Standard***

Function	Signal voltage (U_s)
Neutral	$U_s(\text{pin } 2) = 0.5 \cdot U_{DC}$
Q: P -> A	$U_s(\text{pin } 2) = (0.5 \rightarrow 0.25) \cdot U_{DC}$
Q: P -> B	$U_s(\text{pin } 2) = (0.5 \rightarrow 0.75) \cdot U_{DC}$

Option*

Signal voltage (U_s)
$U_s(\text{pin } 2) = 0.5 \cdot U_{DC}$
$U_s(\text{pin } 2) = (0.5 \rightarrow 0.75) \cdot U_{DC}$
$U_s(\text{pin } 2) = (0.5 \rightarrow 0.25) \cdot U_{DC}$

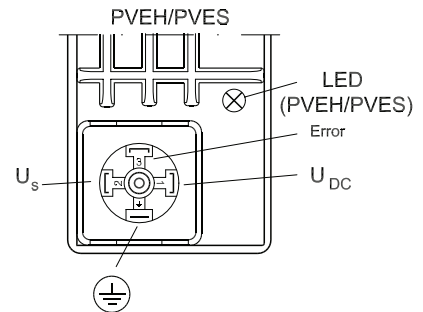

⚠ WARNING

A shut off for pilot oil supply will not bring the spool to neutral on a PVEH. To bring the PVB to neutral shut off power supply or give neutral set point.

**Hirschmann PVEM
Standard***

Function	Signal voltage (U_s)
Neutral	$U_s(\text{pin } 2) = 0.5 \cdot U_{DC}$
Q: P -> A	$U_s(\text{pin } 2) = (0.5 \rightarrow 0.25) \cdot U_{DC}$
Q: P -> B	$U_s(\text{pin } 2) = (0.5 \rightarrow 0.75) \cdot U_{DC}$

Option*

Signal voltage (U_s)
$U_s(\text{pin } 2) = 0.5 \cdot U_{DC}$
$U_s(\text{pin } 2) = (0.5 \rightarrow 0.75) \cdot U_{DC}$
$U_s(\text{pin } 2) = (0.5 \rightarrow 0.25) \cdot U_{DC}$

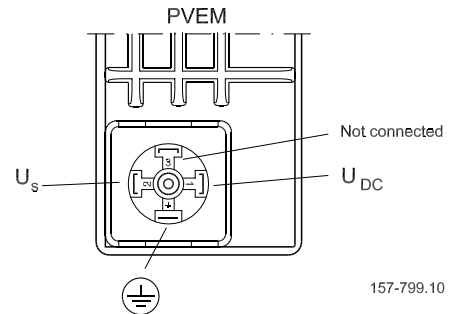

⚠ WARNING

A shut off for pilot oil supply will not bring the spool to neutral on a PVEM. To bring the PVB to neutral shut off power supply or give neutral set point.

* Standard installation: PVM on A-Port side
Option installation: PVM on B-Port side

Standard/Option
Installation
Deutsch-Version

Deutsch-Version on/off
Standard*

Standard*	Signal voltage	
	pin 1	pin 4
Neutral	0	0
Q: P -> A	U_{DC}	0
Q: P -> B	0	U_{DC}

Option*

Signal voltage	
pin 1	pin 4
0	0
0	U_{DC}
U_{DC}	0

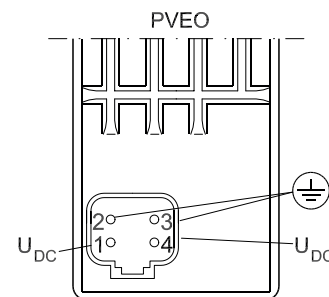

157-760.13

Deutsch-version
PVEA/PVEH/PVES
Standard*

Function	Signal voltage (U_s)
Neutral	$U_s(\text{pin 1}) = 0.5 \cdot U_{DC}$
Q: P -> A	$U_s(\text{pin 1}) = (0.5 \rightarrow 0.25) \cdot U_{DC}$
Q: P -> B	$U_s(\text{pin 1}) = (0.5 \rightarrow 0.75) \cdot U_{DC}$

Option*

Signal voltage (U_s)	
$U_s(\text{pin 1}) = 0.5 \cdot U_{DC}$	
$U_s(\text{pin 1}) = (0.5 \rightarrow 0.75) \cdot U_{DC}$	
$U_s(\text{pin 1}) = (0.5 \rightarrow 0.25) \cdot U_{DC}$	

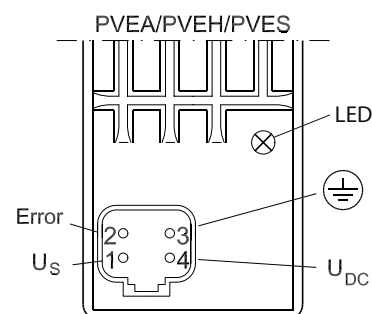

157-759.11

WARNING

A shut off for pilot oil supply will not bring the spool to neutral on a PVEH (-DI/F/SP). To bring the PVB to neutral shut off power supply or give neutral set point.

Deutsch-Version
PVEA-DI/PVEH-DI

On DI versions two U_{DC} connections (U_{DC} and U_{DC2}) are necessary.

- U_{DC} will supply the electronics
- U_{DC2} will supply the solenoid valves

The two ground pins are internally connected.

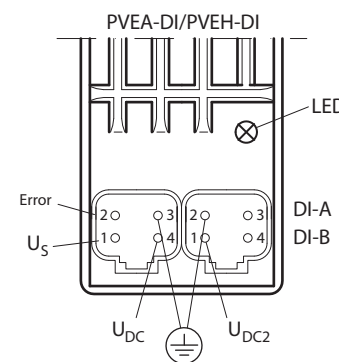

P301 105

Deutsch-Version
PVEH-SP
Standard*

Function	Signal voltage (U_s)
Neutral	$U_s(\text{pin 1}) = 0.5 \cdot U_{DC}$
Q: P -> A	$U_s(\text{pin 1}) = (0.5 \rightarrow 0.25) \cdot U_{DC}$
Q: P -> B	$U_s(\text{pin 1}) = (0.5 \rightarrow 0.75) \cdot U_{DC}$

Option*

Signal voltage (U_s)	
$U_s(\text{pin 1}) = 0.5 \cdot U_{DC}$	
$U_s(\text{pin 1}) = (0.5 \rightarrow 0.75) \cdot U_{DC}$	
$U_s(\text{pin 1}) = (0.5 \rightarrow 0.25) \cdot U_{DC}$	

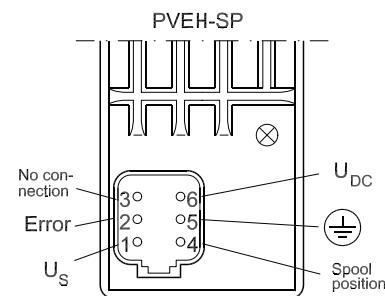

157-800.11

* Standard installation: PVM on A-Port side
Option installation: PVM on B-Port side

**Standard/Option
Installation Deutsch-Version**

**Deutsch-Version PVEH-F
Standard***

Function	Signal voltage	
	(U _s) (pin 1)	Float (pin 5)
Neutral	$0.5 \cdot U_{DC}$	0
Q: -> A	$(0.5 \rightarrow 0.25) \cdot U_{DC}$	0
Q: -> B	$(0.5 \rightarrow 0.75) \cdot U_{DC}$	0
Float	None or any voltage $\leq U_{DC}$	U_{DC}

Option*

Signal voltage	
U _s (pin 1)	Float (pin 5)
$0.5 \cdot U_{DC}$	0
$(0.5 \rightarrow 0.75) \cdot U_{DC}$	0
$(0.5 \rightarrow 0.25) \cdot U_{DC}$	0
None or any voltage $\leq U_{DC}$	U_{DC}

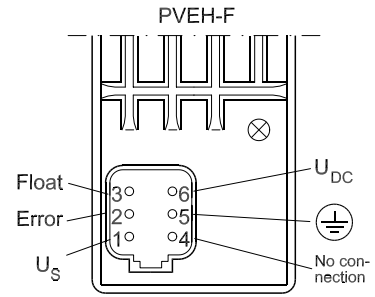

157-779.11

**Deutsch-Version
PVED-CC**

V_{bat}: 11 - 32 V DC
CAN-L / CAN-H digital signal.
The pins are internally connected.
For control, see technical information
Electro hydraulic actuator type PVED-CC
(520L0665).

* Standard installation: PVM on A-Port side
Option installation: PVM on B-Port side

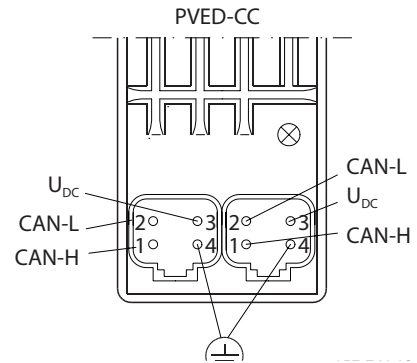

Installation

PVE Fault Monitoring

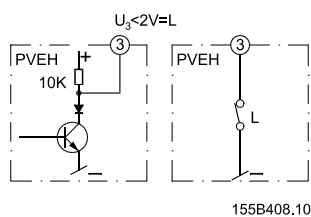

155B408.10

Green

Normal

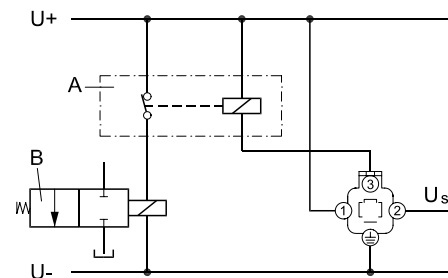

155B406.10

A: External relay
B: Solenoid valve

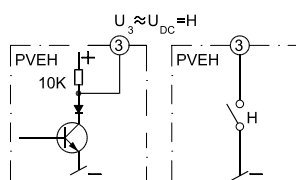

155B409.1

Red

Fault

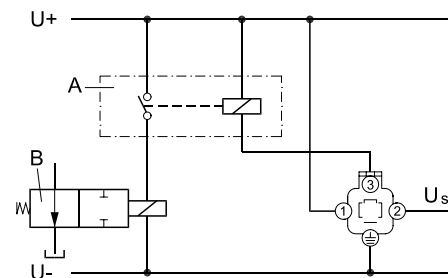

155B407.10

A: External relay
B: Solenoid valve

Installation

PVE Fault Monitoring

Reaction Time

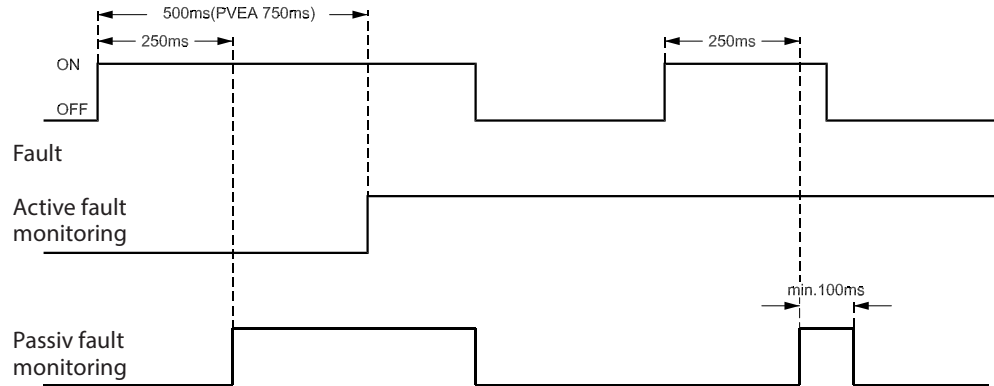

155B492.10

Block Diagram

Active

- (a): Cut-off of solenoid valves
- (b): Control signal for LED
- (c): Control signal for alarm output

Passive

- (a): Does not exist
- (b): Control signal for LED
- (c): Control signal for alarm output

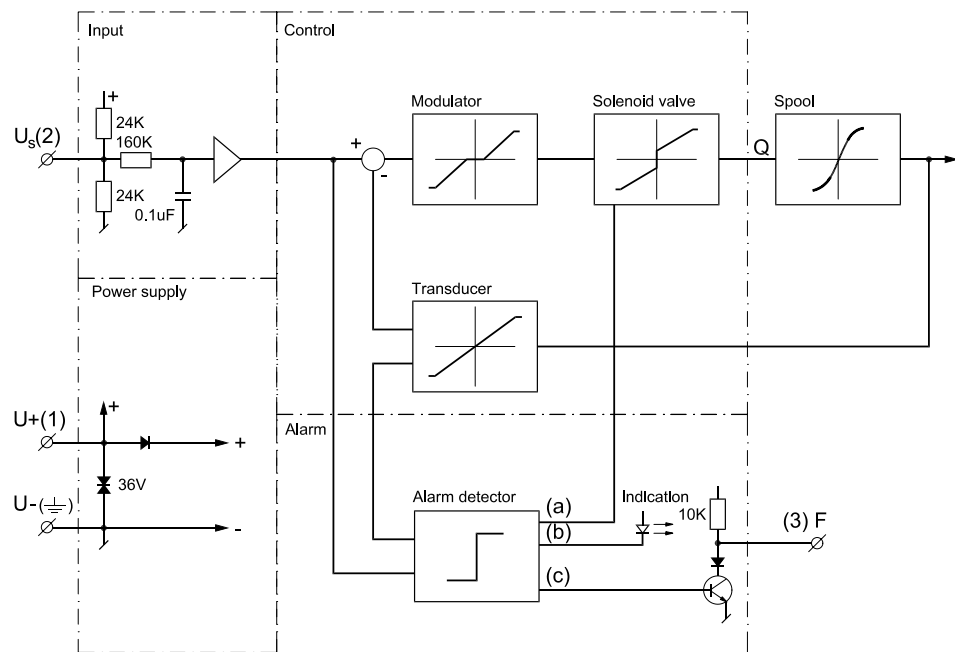

157-275.10

Installation

PVEH / PVEM / PVES

Check max. lever travel in neutral position

1. Make sure the system is supplied with hydraulic power
2. Connect supply voltage (U_{DC}) (Signal voltage = $0,5 \times U_{DC}$), or cut off the signal voltage (U_s) on pin 2.

Adjustment of PVE When Max. Lever Travel is Exceeded (PVE is Factory-Preset)

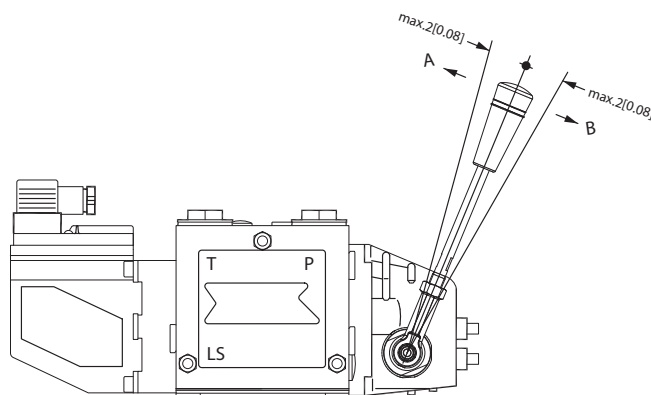

V310107.A

Lever Travel Exceeded in

PVG 32

Direction of rotation for adjustment of position Transducer

WARNING

Doing this adjustment on a PVED will compromise safety surveillance.

Direction A

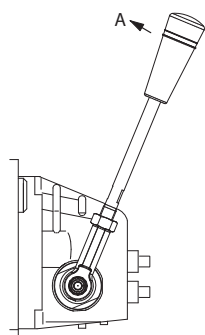

Direction B

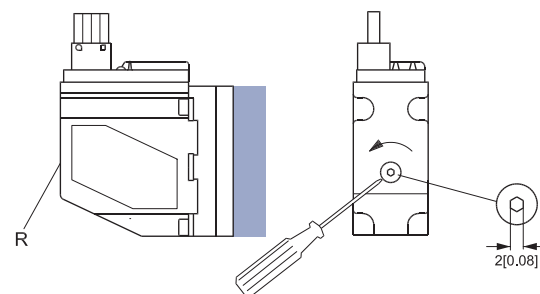

V310177.A

157-325.12.20

The cap protecting the screw is a part of the IP classification.

Every PVE is individually factory calibrated. Any mechanical adjustment will make the PVE less accurate.

Manual adjustment should only be a temporary solution

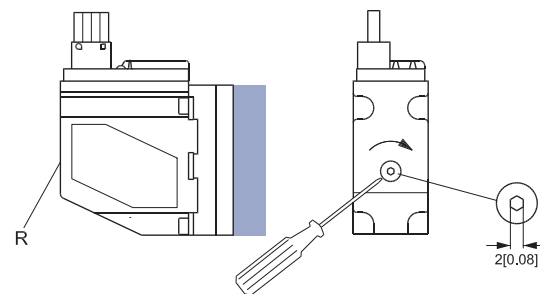
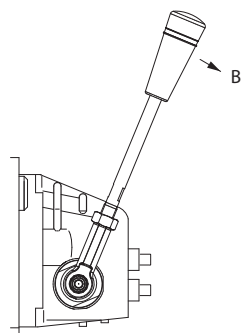

V310108.A

157-325.12.10

Turn of Transducer	Movement of Lever
1/4	1.5 mm [0.06 in]
1/2	3.0 mm [0.12 in]
3/4	4.5 mm [0.18 in]

Installation

Installation of PVE

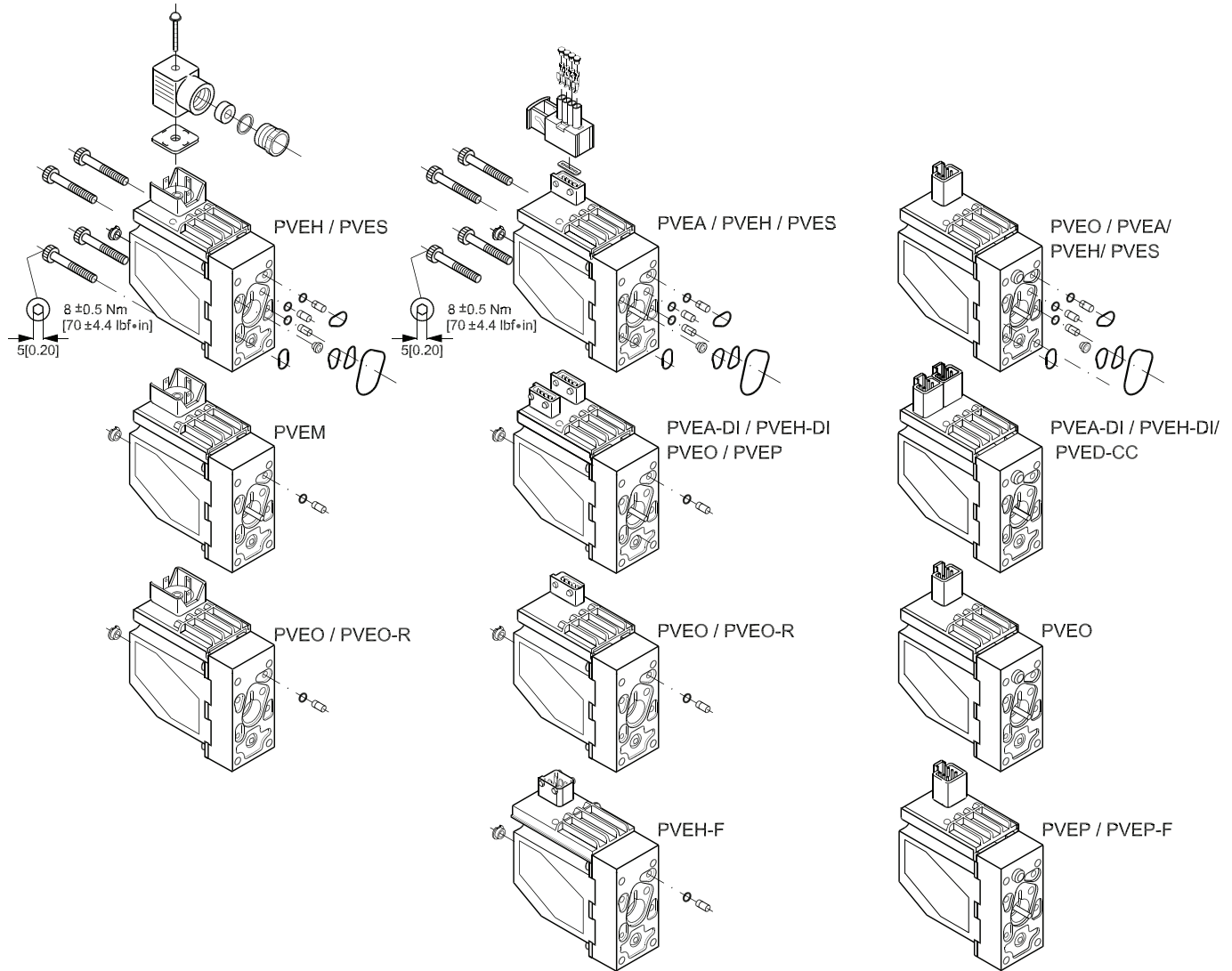

157-585.14

Installation

Connections,
Pump Side Module, PVP

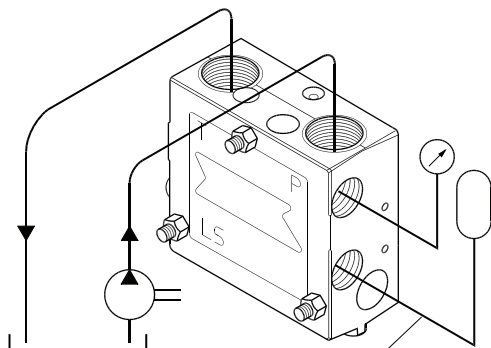

Accumulator port

157-81.13

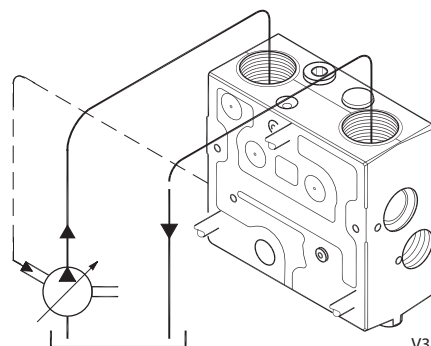

V310183.A

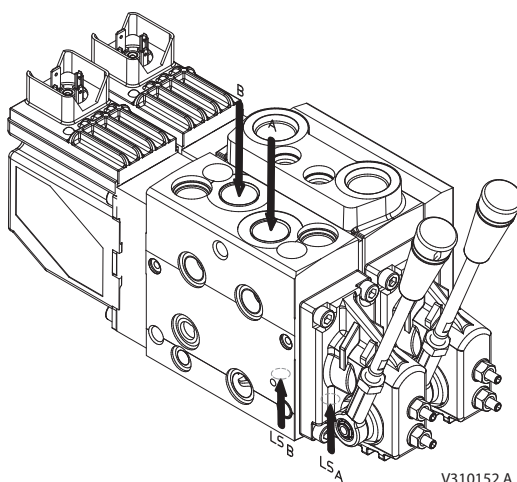

V310152.A

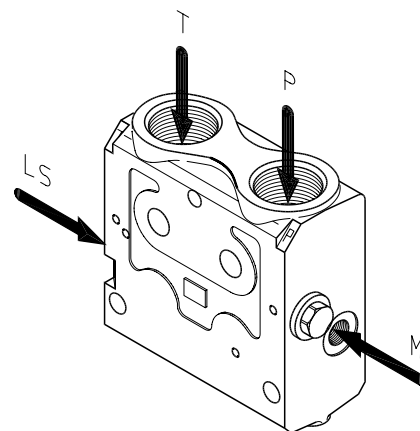

157B351.10

Max. Tightening Torque	Connection								
	P			A/B	T	LS, M, LSA, LSB, T0, PVH, Pp Accu.	LX		
							PVS	PVSI	
Connectors BSP	G $\frac{1}{2}$	G $\frac{3}{4}$	1 in	G $\frac{1}{2}$	G $\frac{3}{4}$	1 in	G $\frac{1}{4}$	G $\frac{1}{8}$	G $\frac{1}{4}$
With steel washer	130 N·m [1150 lbf·in]	210 N·m [1850 lbf·in]	280 N·m [2460 lbf·in]	130 N·m [1150 lbf·in]	210 N·m [1850 lbf·in]	280 N·m [2460 lbf·in]	40 N·m [350 lbf·in]	17 N·m [150 lbf·in]	40 N·m [350 lbf·in]
With copper washer	30 N·m [270 lbf·in]	50 N·m [445 lbf·in]	70 N·m [620 lbf·in]	30 N·m [270 lbf·in]	50 N·m [445 lbf·in]	70 N·m [620 lbf·in]	20 N·m [180 lbf·in]	15 N·m [135 lbf·in]	20 N·m [180 lbf·in]
With aluminium washer	70 N·m [620 lbf·in]	110 N·m [970 lbf·in]	170 N·m [1500 lbf·in]	70 N·m [620 lbf·in]	110 N·m [970 lbf·in]	170 N·m [1500 lbf·in]	30 N·m [270 lbf·in]	15 N·m [135 lbf·in]	30 N·m [270 lbf·in]
With cutting edge	130 N·m [1150 lbf·in]	210 N·m [1850 lbf·in]	280 N·m [2460 lbf·in]	130 N·m [1150 lbf·in]	210 N·m [1850 lbf·in]	280 N·m [2460 lbf·in]	40 N·m [350 lbf·in]	17 N·m [150 lbf·in]	40 N·m [350 lbf·in]
Connectors SAE	G $\frac{7}{8}$ in - 14	G $\frac{11}{16}$ in - 12	1 $\frac{5}{16}$ in - 12	G $\frac{7}{8}$ in - 14	G $\frac{11}{16}$ in - 12	1 $\frac{5}{16}$ in - 12	$\frac{1}{2}$ in - 20	G $\frac{1}{8}$ in - 24	$\frac{1}{2}$ in - 20
O - ring	90 N·m [800 lbf·in]	120 N·m [1060 lbf·in]	160 N·m [1410 lbf·in]	90 N·m [800 lbf·in]	120 N·m [1060 lbf·in]	160 N·m [1410 lbf·in]	30 N·m [270 lbf·in]	10 N·m [90 lbf·in]	30 N·m [270 lbf·in]

Installation

Installation of Lever

Screw the Lever Completely Home

Base with an angle of 22.5°

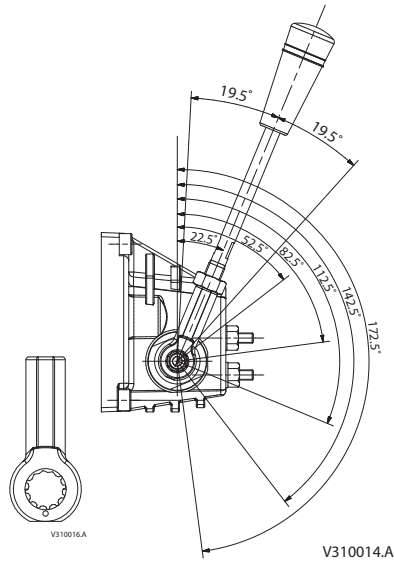

Base with an angle of 37.5°

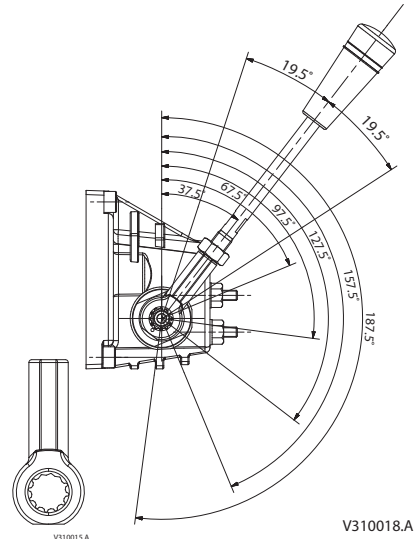

Pressure Setting
PVP, LS_A, LS_B

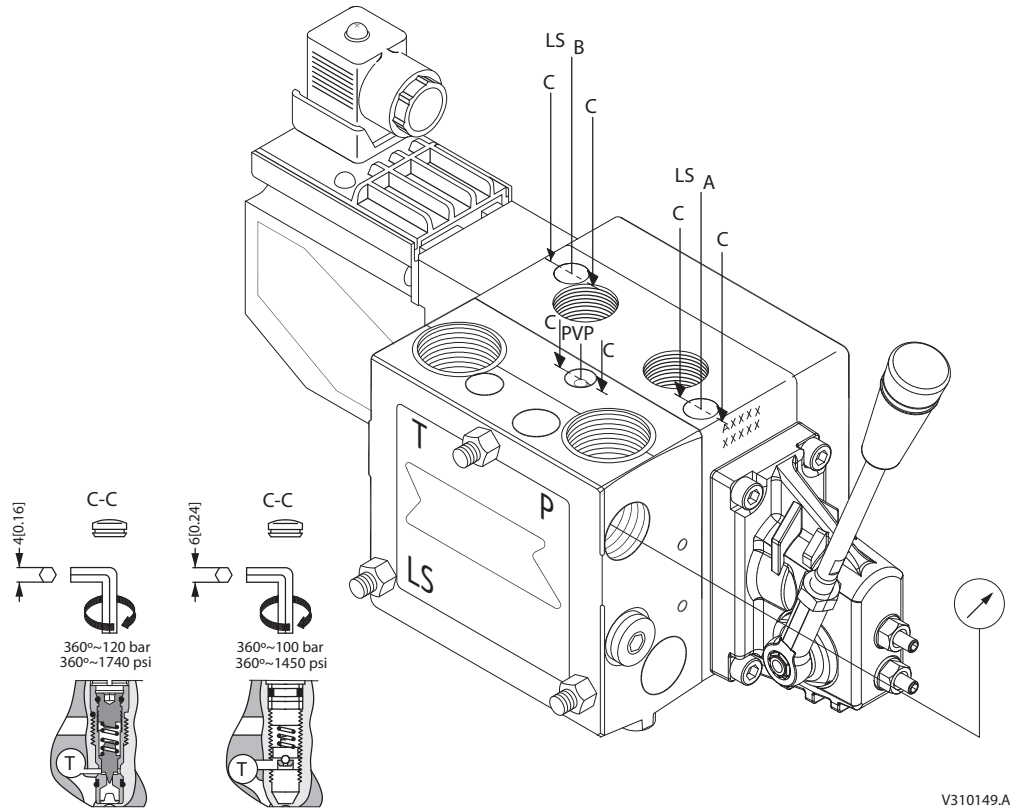

V310149.A

	Before week 40/2003	Week 40/2003 - week 2/2004	After week 2/2004
Relief valve 1	x	x	
Relief valve 2		x	x

Installation

Bleeding

(If the valve group is installed as shown, it is recommended to bleed the valve at the PVM adjusting screws A)

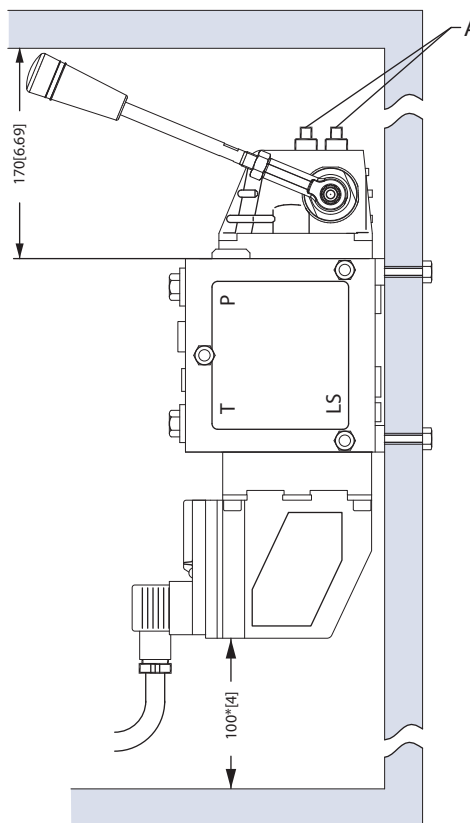

V310109.A

Installation

Installation and Technical Data for PVPX

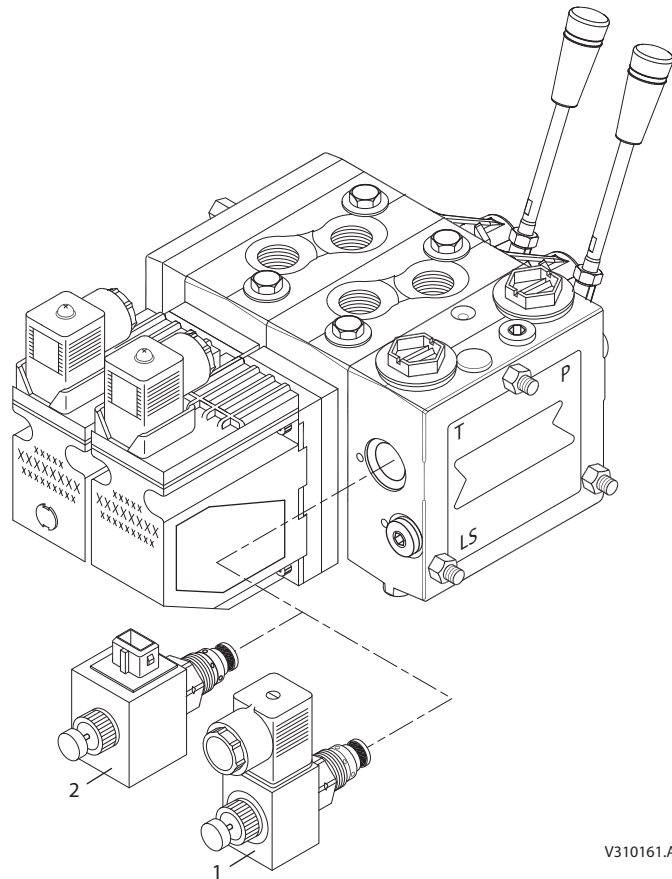

V310161.A

Position	Across Flats	Max. Tightening Torque
1 and 2	24 mm [0.94 in]	45 N·m [400 lbf·in]

Max operation pressure		350 bar [5076 psi]	
Max. coil surface temperature		155°C [311°F]	
Rated voltage		12 V	24 V
Current consumption	22°C [71.6°F] coil temperature	1.55 A	0.78 A
	110°C [230°F] coil temperature	1.00 A	0.50 A
Power consumption	22°C [71.6°F] coil temperature	19 W	19 W
	110°C [230°F] coil temperature	12 W	12 W
Max. permissible deviation from rated supply voltage		±10%	

Installation

**PVPX Installation
Hirschmann
Connector**

When installing the wire remember to connect the built-in diode to the plug pins.

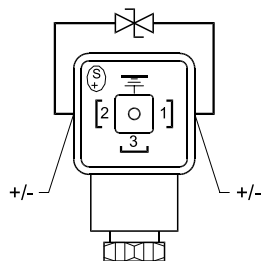

157-201.10

**PVPX Installation
AMP Connector**

The AMP plug contains no integrated diode. PVPX control circuit protection must thus be installed externally, possible by means of a (36 V suppressor diode, BZW04) in the terminal block.

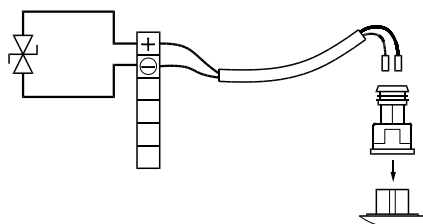

157-413.10

Installation

Assembly for PVMR / F

1

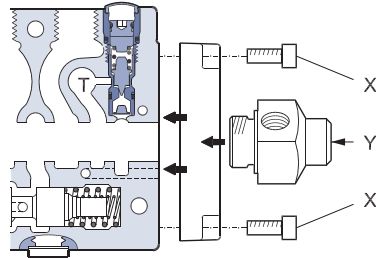

157-224.11

2

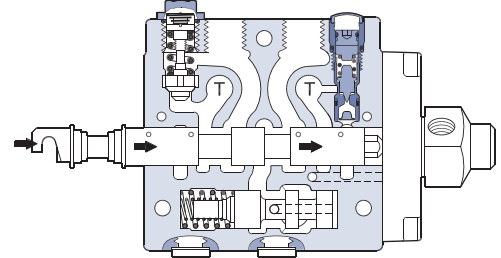

157-225.11

3

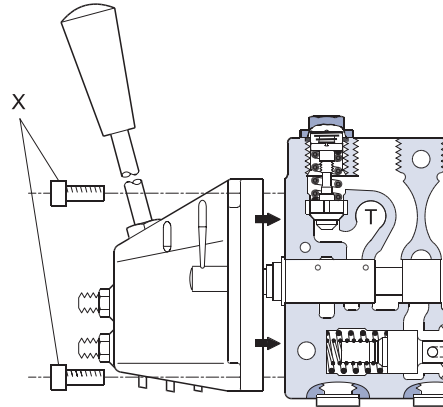

157-226.10

4

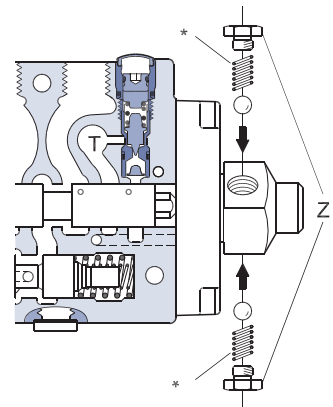

157-227.11

Tightening Torques and Widths Across Flats

*	Spring Identification
PVMF	Painted blue
PVMR	Non-painted

	X	Y	Z
With across flats			
Tightening torque	8 ± 0.5 N·m [70 ± 4.5 lbf·in]	15 ± 2 N·m [135 ± 20 lbf·in]	4 ± 1 N·m [35 ± 9 lbf·in]

Installation

Dismantling for PVMR / F

1

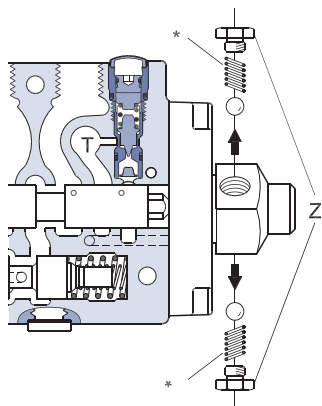

157-228.11

2

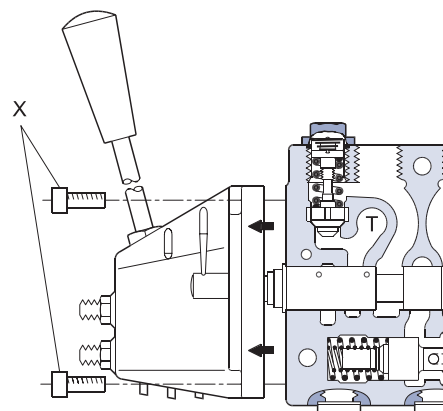

157-229.10

3

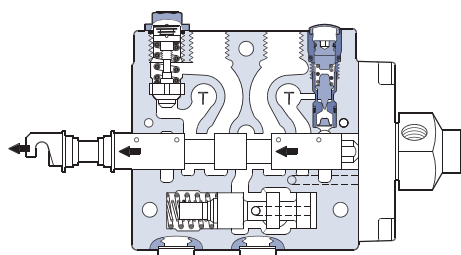

157-230.11

4

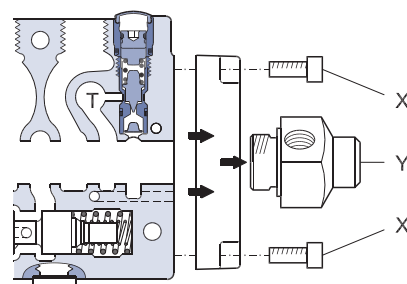

157-231.11

Installation

Standard Main Spool
→ Main Spool
for PVMR

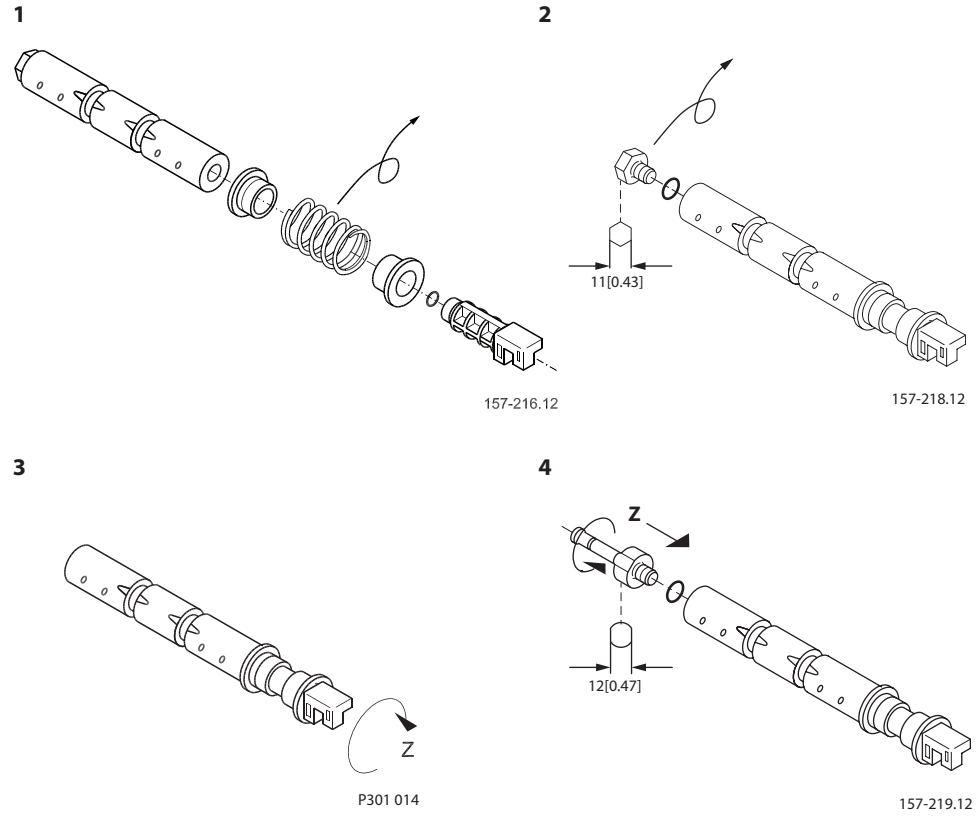

Z	8 ±1 N•m [70±9 lbf•in]
---	------------------------

Installation

Standard Float Position
Spool → Float Position
Spool for PVMF

P → B → F

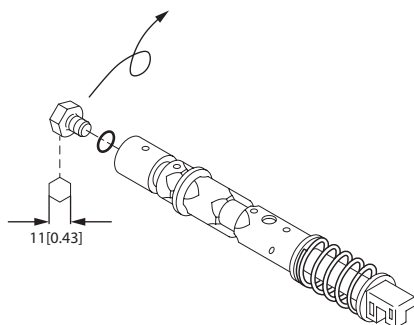

157-234.12

P → A → F

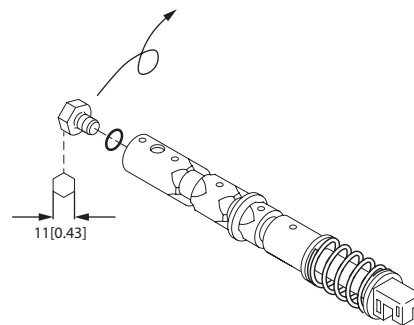

157-220.11

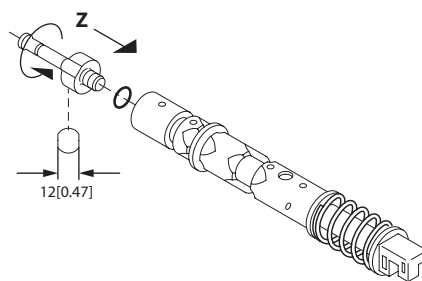

157-233.12

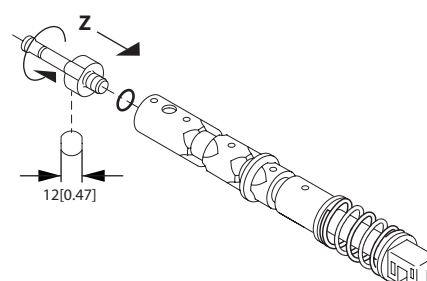

157-221.12

z	$8 \pm 1 \text{ N}\cdot\text{m} [70 \pm 9 \text{ lbf}\cdot\text{in}]$
---	---

PVP

VVP, Pump Side Module

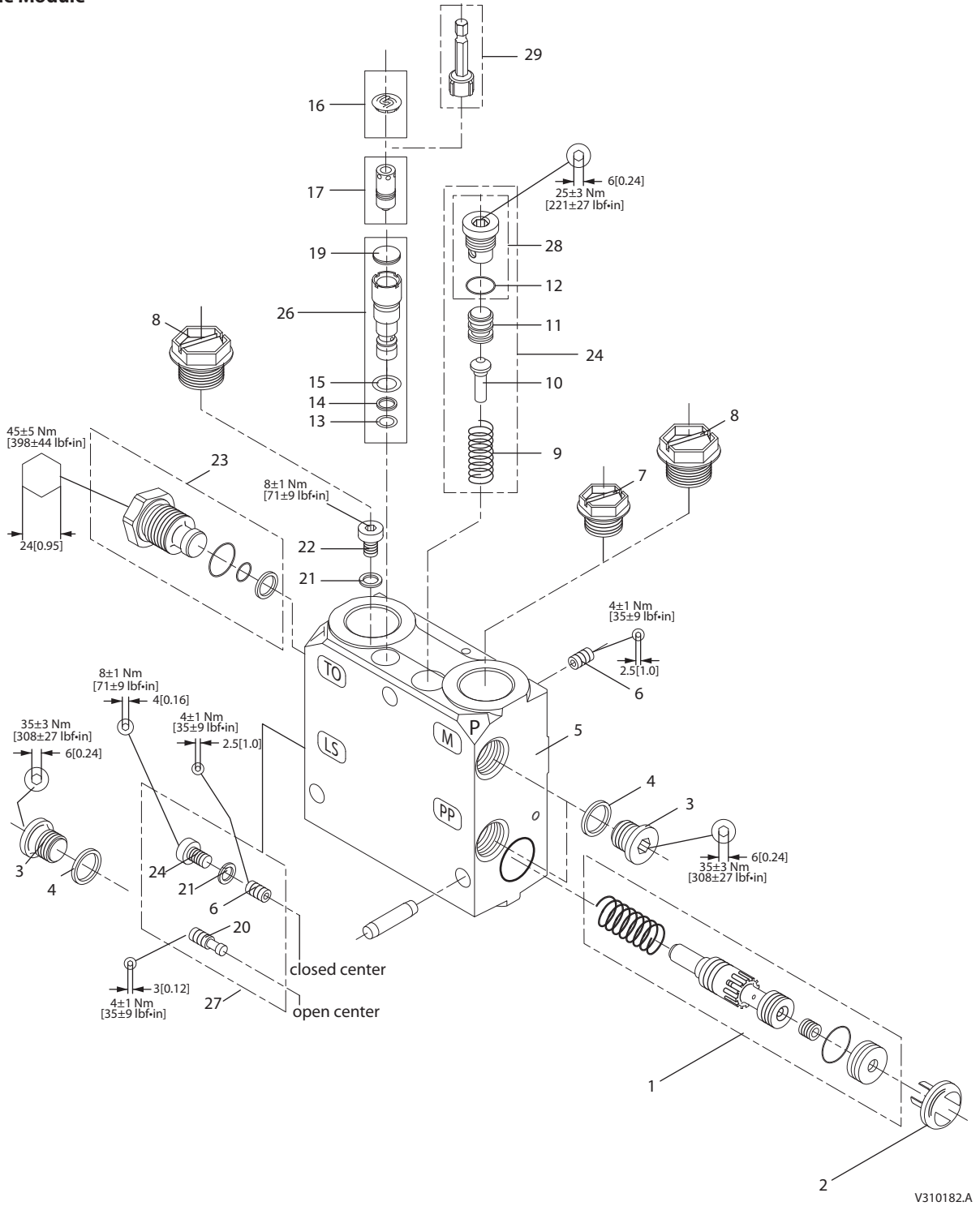

V310182.A

Spare Parts PVP

PVP, Pump Side Module

Type		Code no.		
		BSP - thread	SAE-thread	
PVP Open center	P-port< = G $\frac{1}{2}$ / $\frac{7}{8}$ - 14 T-port< = G $\frac{3}{4}$ / 1 $\frac{1}{16}$ - 12	Excl. pilot supply for PVE	157B5000	157B5200
PVP Open center	P-port< = G $\frac{3}{4}$ / 1 $\frac{1}{16}$ - 12		157B5100	157B5300
PVP Closed center	P-port< = G $\frac{1}{2}$ / $\frac{7}{8}$ - 14 T-port< = G $\frac{3}{4}$ / 1 $\frac{1}{16}$ - 12		157B5001	157B5201
PVP Closed center	P-port< = G $\frac{3}{4}$ / 1 $\frac{1}{16}$ - 12		157B5101	157B5301
PVP Open center	P-port< = G $\frac{3}{4}$	Excl. pilot supply for PVE With facilities for PVPX	157B5102	-
PVP Closed center	P-port< = G $\frac{3}{4}$		157B5103	-
PVP Open center	P-port< = G $\frac{1}{2}$ / $\frac{7}{8}$ - 14 T-port< = G $\frac{3}{4}$ / 1 $\frac{1}{16}$ - 12	Incl. pilot supply for PVE	157B5010	157B5210
PVP Open center	P-port< = G $\frac{3}{4}$ / 1 $\frac{1}{16}$ - 12		157B5110	157B5310
PVP Closed center	P-port< = G $\frac{1}{2}$ / $\frac{7}{8}$ - 14 T-port< = G $\frac{3}{4}$ / 1 $\frac{1}{16}$ - 12		157B5011	157B5211
PVP Closed center	P-port< = G $\frac{3}{4}$ / 1 $\frac{1}{16}$ - 12		157B5111	157B5311

Item	Description										
1	Inlet compensator, assy	1	1	1	1	1	1	1	1	1	1
2	Plastic plug	1	1	1	1	1	1	1	1	1	1
3	Plug	G $\frac{1}{4}$ - thread	2	2	2	2	2	2	2	2	2
		$\frac{1}{2}$ - 20 UNF - thread	2	2	2	2			2	2	2
4*	Washer 13.5 • 17.5 • 1.5 [0.53 • 0.69 • 0.06 in]	BSP/SAE	2	2	2	2	2	2	2	2	2
5	Housing		1	1	1	1	1	1	1	1	1
6	Orifice \varnothing 1.0 • M6 [0.04 in • M6]		2	2	1	1	1	2	2	2	1
7	Plastic plug	G $\frac{1}{2}$ - thread		1		1				1	1
		$\frac{7}{8}$ -14 UNF - thread		1		1				1	1
8	Plastic plug	G $\frac{3}{4}$ - thread	2	1	2	1	2	2	2	1	2
		1 $\frac{1}{16}$ - 12 UNF-thread	2	1	2	1			2	1	2
9	Spring		1	1	1	1					
10	Cone		1	1	1	1					
11	Spool		1	1	1	1					
12*	O-ring \varnothing 11.0 • 2.0 [0.43 • 0.08 in]		1	1	1	1					
13	O-ring \varnothing 8.0 • 1.5 [0.31 • 0.06 in]		1	1	1	1	1	1	1	1	1
14	Back up ring DTM		1	1	1	1	1	1	1	1	1
15	O-ring \varnothing 11.0 • 2.0 [0.43 • 0.08 in]		1	1	1	1	1	1	1	1	1
19	Plastic plug		1	1	1	1	1	1	1	1	1
20	Plug M6. open center only				1	1				1	1
21*	Bonded seal 6.7 • 10 • 1.0 [0.26 • 0.39 • 0.04 in]		1	1			1	2	1	1	
22	Screw M6		1	1			1	2	1	1	

PVP

VVP, Pump Side Module

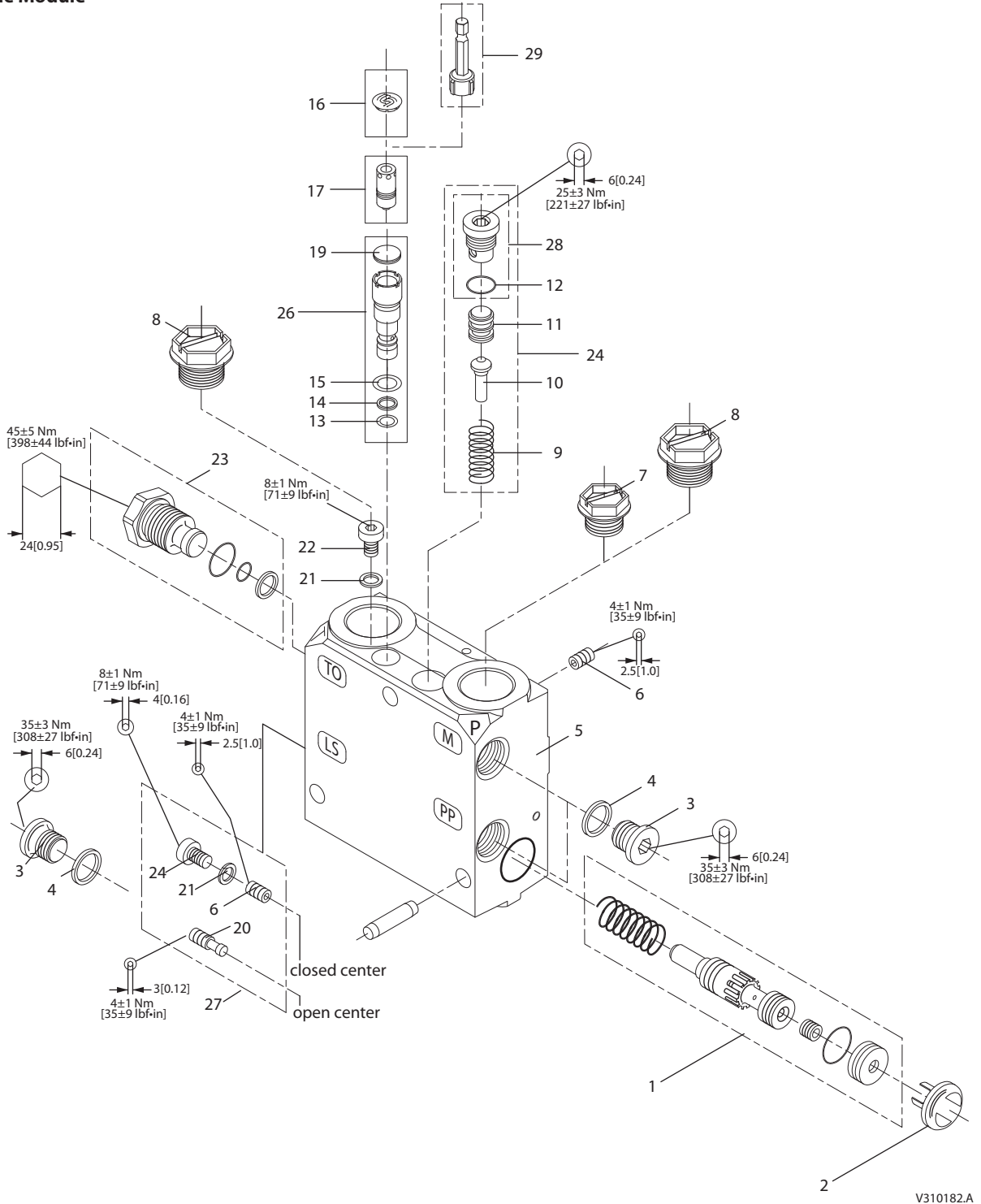

Spare Parts PVP

PVP, Pump Side Module (Continued)

Type	Code no.		
	BSP - thread	SAE-thread	
PVP Open center P-port < = G $\frac{1}{2}$ / $\frac{7}{8}$ - 14 T-port < = G $\frac{3}{4}$ / 1/16 - 12	Incl. pilot supply for PVE and facilities for PVPX	157B5012	157B5212
PVP Open center P-port < = G $\frac{3}{4}$ / 1/16 - 12 T-port < = G $\frac{3}{4}$ / 1/16 - 12		157B5112	157B5312
PVP Closed center P-port < = G $\frac{1}{2}$ / $\frac{7}{8}$ - 14 T-port < = G $\frac{3}{4}$ / 1/16 - 12		157B5013	157B5213
PVP Closed center P-port < = G $\frac{3}{4}$ / 1/16 - 12 T-port < = G $\frac{3}{4}$ / 1/16 - 12		157B5113	157B5313
PVP Open center P-port < = G $\frac{3}{4}$ T-port < = G $\frac{3}{4}$	Excl. pilot supply for PVE With facilities for PVPX	157B5102	-
PVP Closed center P-port < = G $\frac{3}{4}$ T-port < = G $\frac{3}{4}$		157B5103	-
PVP Open center P-port < = G $\frac{1}{2}$ / $\frac{7}{8}$ - 14 T-port < = G $\frac{3}{4}$ / 1/16 - 12	Incl. pilot supply for PVE	157B5010	157B5210
PVP Open center P-port < = G $\frac{3}{4}$ / 1/16 - 12 T-port < = G $\frac{3}{4}$ / 1/16 - 12		157B5110	157B5310
PVP Closed center P-port < = G $\frac{1}{2}$ / $\frac{7}{8}$ - 14 T-port < = G $\frac{3}{4}$ / 1/16 - 12		157B5011	157B5211
PVP Closed center P-port < = G $\frac{3}{4}$ / 1/16 - 12 T-port < = G $\frac{3}{4}$ / 1/16 - 12		157B5111	157B5311

Sparepart Kits Available

Item	Description	Code no.												
16	Sealed plastic adjusting screw, black (50 pcs.)	155L6168	1	1	1	1	1	1	1	1				
16	Sealed plastic adjusting screw, yellow (50 pcs.)	155L6167	1	1	1	1	1	1	1	1				
17	Sealed adjusting screw (for sealing with a wire)	155L6489	1	1	1	1	1	1	1	1				
23**	PVPX plug (see page 51)	157B5601					1	1	1	1	1	1	1	1
24	Pilot supply	155L5157	1	1	1	1								
25	Relief valve	155L6495	1	1	1	1	1	1	1	1	1	1	1	1
26	Conversion kit open to closed - and closed to open - center	155L5152			1	1		1					1	1
27	Plug (incl. item 12*)	155L5150	1	1	1	1								
28	Service tool for relief valve	155L6494	1	1	1	1	1	1	1	1	1	1	1	1
*	Set of seals, PVP (see page 64)	157B5999	1	1	1	1	1	1	1	1	1	1	1	1
**	Set of seals, PVPX (see page 64)	157B4996					1	1	1	1				

PVP

PVP, Pump Side Module
(Continued)

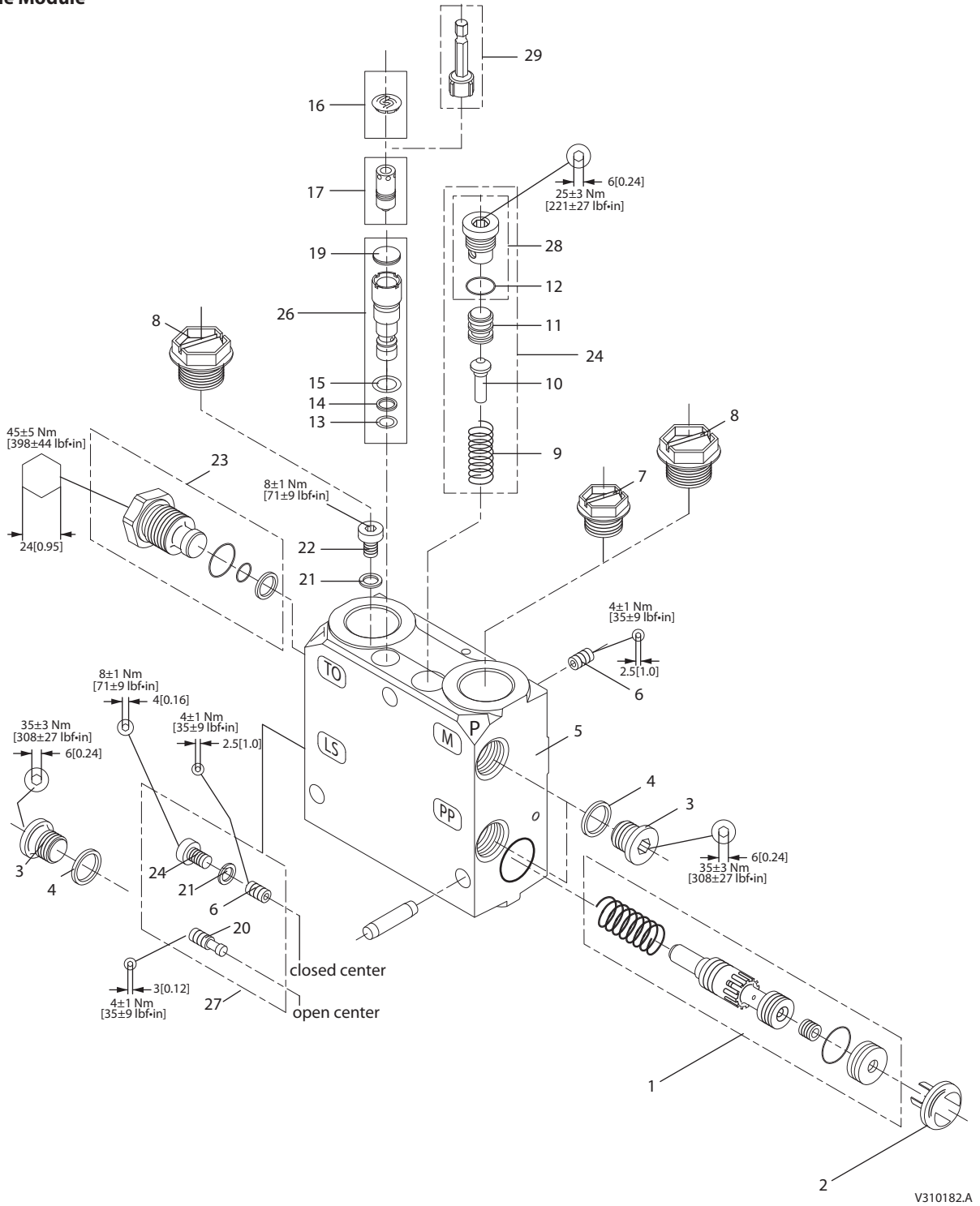

Spare Parts PVP

PVP, Pump Side Module (Continued)

Type		Code no.			
		BSP - thread	SAE-thread		
PVP Open center	P-port< = G $\frac{1}{2}$ / $\frac{7}{8}$ - 14 T-port< = G $\frac{3}{4}$ / 1 $\frac{1}{16}$ - 12	Incl. pilot supply for PVE and facilities for PVPX	157B5012	157B5212	
PVP Open center	P-port< = G $\frac{3}{4}$ / 1 $\frac{1}{16}$ - 12		157B5112	157B5312	
PVP Closed center	P-port< = G $\frac{1}{2}$ / $\frac{7}{8}$ - 14 T-port< = G $\frac{3}{4}$ / 1 $\frac{1}{16}$ - 12		157B5013	157B5213	
PVP Closed center	P-port< = G $\frac{3}{4}$ / 1 $\frac{1}{16}$ - 12		157B5113	157B5313	
PVP Open center	P-port< = G $\frac{3}{4}$ / 1 $\frac{1}{16}$ - 12		Incl. pilot supply for PVE and external PVPX	157B5180	157B5380
PVP Closed center	P-port< = G $\frac{3}{4}$ / 1 $\frac{1}{16}$ - 12			157B5181	157B5381
PVP Open center	P-port< = G $\frac{3}{4}$ / 1 $\frac{1}{16}$ - 12		Incl. pilot supply for hydraulic activation and external Pp	157B5190	157B5390
PVP Closed	P-port< = G $\frac{3}{4}$ / 1 $\frac{1}{16}$ - 12			157B5191	157B5391

Sparepart Kits Available

Item	Description								
1	Inlet compensator	1	1	1	1	1	1	1	1
2	Plastic plug	1	1	1	1	1	1	1	1
3	Plug	G $\frac{1}{4}$ - thread	3	3	3	3	2	2	2
		$\frac{1}{2}$ - 20 UNF - thread					2	2	2
4*	Washer 13.5 • 17.5 • 1.5 [0.53 • 0.69 • 0.06 in]	G / UNF - thread	3	3	3	3	2	2	2
5	Housing		1	1	1	1	1	1	1
6	Orifice \varnothing 1.0 • M6 [0.04 in • M6]		2	1	2	1	2	2	1
7	Plastic plug	G $\frac{1}{2}$ - thread						1	1
		$\frac{7}{8}$ -14 UNF - thread						1	1
8	Plastic plug	G $\frac{3}{4}$ - thread	2	2	2	2	2	1	2
		1 $\frac{1}{16}$ - 12 UNF-thread					2	1	2
9	Spring		1	1	1	1	1	1	1
10	Cone		1	1	1	1	1	1	1
11	Spool		1	1	1	1	1	1	1
12*	O-ring \varnothing 11.0 • 2.0 [0.43 • 0.08 in]		1	1	1	1	1	1	1
13	O-ring \varnothing 8.0 • 1.5 [0.32 • 0.06 in]		1	1	1	1	1	1	1
14	Back-up ring		1	1	1	1	1	1	1
15	O-ring \varnothing 11.0 • 2.0 [0.43 • 0.08 in]		1	1	1	1	1	1	1
19*	Plastic plug		1	1	1	1	1	1	1
20	Plug M6			1	1			1	1
21*	Bonded seal 6.7 • 10 • 1.0 [0.26 • 0.39 • 0.04 in]		1		1		2	2	1
22	Screw M6		1		1		2	2	1

Spare Parts PVP

PVP, Pump Side Module (Continued)

Type		Code no.			
		BSP - thread	SAE-thread		
PVP Open center	P-port< = G $\frac{1}{2}$ / $\frac{7}{8}$ - 14 T-port< = G $\frac{3}{4}$ / $\frac{1}{16}$ - 12	Incl. pilot supply for PVE and facilities for PVPX	157B5012	157B5212	
PVP Open center	P-port< = G $\frac{3}{4}$ / $\frac{1}{16}$ - 12 T-port< = G $\frac{3}{4}$ / $\frac{1}{16}$ - 12		157B5112	157B5312	
PVP Closed center	P-port< = G $\frac{1}{2}$ / $\frac{7}{8}$ - 14 T-port< = G $\frac{3}{4}$ / $\frac{1}{16}$ - 12		157B5013	157B5213	
PVP Closed center	P-port< = G $\frac{3}{4}$ / $\frac{1}{16}$ - 12 T-port< = G $\frac{3}{4}$ / $\frac{1}{16}$ - 12		157B5113	157B5313	
PVP Open center	P-port< = G $\frac{3}{4}$ / $\frac{1}{16}$ - 12 T-port< = G $\frac{3}{4}$ / $\frac{1}{16}$ - 12		Incl. pilot supply for PVE and external PVPX	157B5180	157B5380
PVP Closed center	P-port< = G $\frac{3}{4}$ / $\frac{1}{16}$ - 12 T-port< = G $\frac{3}{4}$ / $\frac{1}{16}$ - 12		157B5181	157B5381	
PVP Open center	P-port< = G $\frac{3}{4}$ / $\frac{1}{16}$ - 12 T-port< = G $\frac{3}{4}$ / $\frac{1}{16}$ - 12		Incl. pilot supply for hydraulic activation and external Pp	157B5190	157B5390
PVP Closed	P-port< = G $\frac{3}{4}$ / $\frac{1}{16}$ - 12 T-port< = G $\frac{3}{4}$ / $\frac{1}{16}$ - 12		157B5191	157B5391	

Sparepart Kits Available

Item	Description	Code no.									
16	Sealed plastic adjusting screw. yellow (50pcs)	155L6167	1	1	1	1	1	1	1	1	1
16	Sealed plastic adjusting screw, black (50pcs)	155L6168	1	1	1	1	1	1	1	1	1
17	Sealed adjusting screw (for sealing with a wire)	155L6489	1	1	1	1	1	1	1	1	1
23**	PVPX plug (see page 51)	157B5601					1	1	1	1	1
24	Pilot supply	155L5157			1	1	1	1	1	1	1
25	Pilot, hydraulic activation	11077272	1	1							
26	Relief valve	155L6495	1	1	1	1	1	1	1	1	1
27	Conversion kit open to closed - and closed to open - center	155L5152		1	1		1		1	1	1
28	Plug (incl. item 12*)	155L5150	1	1	1	1	1	1	1	1	1
29	Service tool for relief valve	155L6494	1	1	1	1	1	1	1	1	1
*	Set of seals (see page 66)	157B5999	1	1	1	1	1	1	1	1	1
**	Set of seals (see page 66)	157B4996					1	1	1	1	1

PVPV/M

PVPV/M,
Pump Side Module

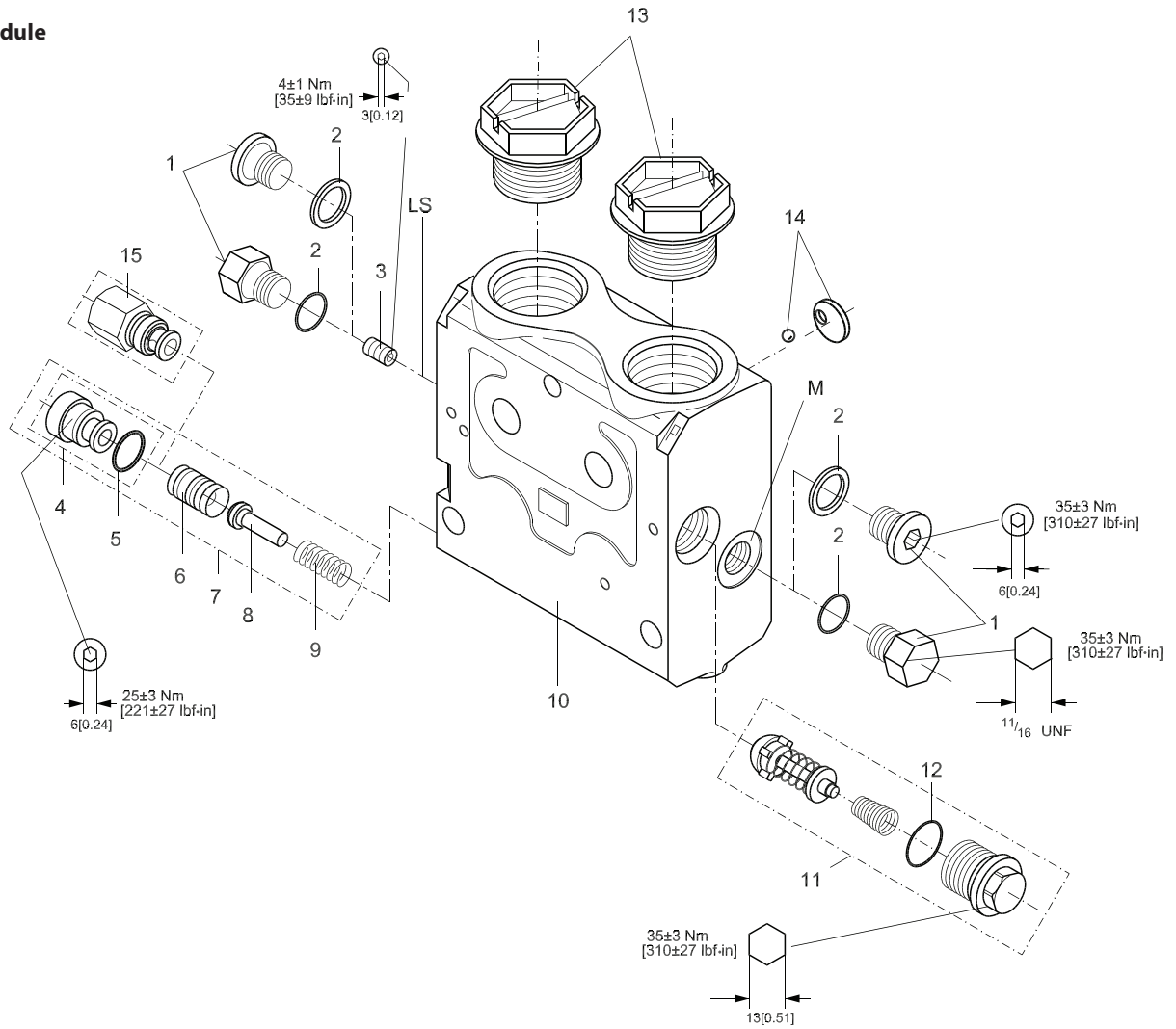

157-328.12

Spare Parts PVPV/M

PVPV/M, Pump Side Module

Type	Code no.	
	BSP - thread	SAE-thread
PVP Closed center P/T-port< = G1 1 5/16 UN	157B5938	-
	-	157B5911
PVP Closed center P/T-port< = G1 1 5/16 UN	157B5937	-
	-	157B5912
PVP Closed center P/T-port< = G1 1 5/16 UN	157B5941	-
	-	157B5913
PVP Closed center P/T-port< = G1 1 5/16 UN	157B5940	-
	-	157B5914

Item	Description									
1	Plug	G 1/4		2		2		2		2
		9/16 - 18 UNF	2		2		2		2	
2	Washer 13.5 • 17.5 • 1.5 [0.53 • 0.69 • 0.06 in] O-ring Ø11.89 • 1.98 [0.47 • 0.08 in]			1		1		1		2
			1		1		1		1	
3	Orifice Ø1.0 • M6 [0.04 • M6]		1	1	1	1	1	1	1	1
4	Plug (incl. item 5)		1	1	1	1	1	1	1	1
5	O-ring Ø11.0 • 2.0 [0.43 • 0.08 in]		1	1	1	1	1	1	1	1
6	Spool		1	1	1	1	1	1	1	1
8	Cone		1	1	1	1	1	1	1	1
9	Spring		1	1	1	1	1	1	1	1
10	Housing		1	1	1	1	1	1	1	1
12	O-ring Ø15.6 • 1.78 [0.61 • 0.07 in]		1	1	1	1				
13	Plastic plug	G 1		2		2		2		2
		1 5/16 - 18 UNF	2		2		2		2	
14	Shuttle assy.		1	1			1	1		
'	Set of seals (see page 66)		1	1	1	1	1	1	1	1

Sparepart Kits Available

Item	Description	Code no.							
7	Pilot supply	155L5157	1	1	1	1	1	1	1
11	PVLP shock valve see page 42, 43		1	1	1	1			
15	Plug for external Pp	11038675	1	1	1	1	1	1	1
*	Set of seals Page 64	157B5999	1	1	1	1	1	1	1

PVB

PVB, Basic Module

PVLA,
Anti-Cavitation Valve

PVLP,
Shock and Anti-Cavitation
Valve

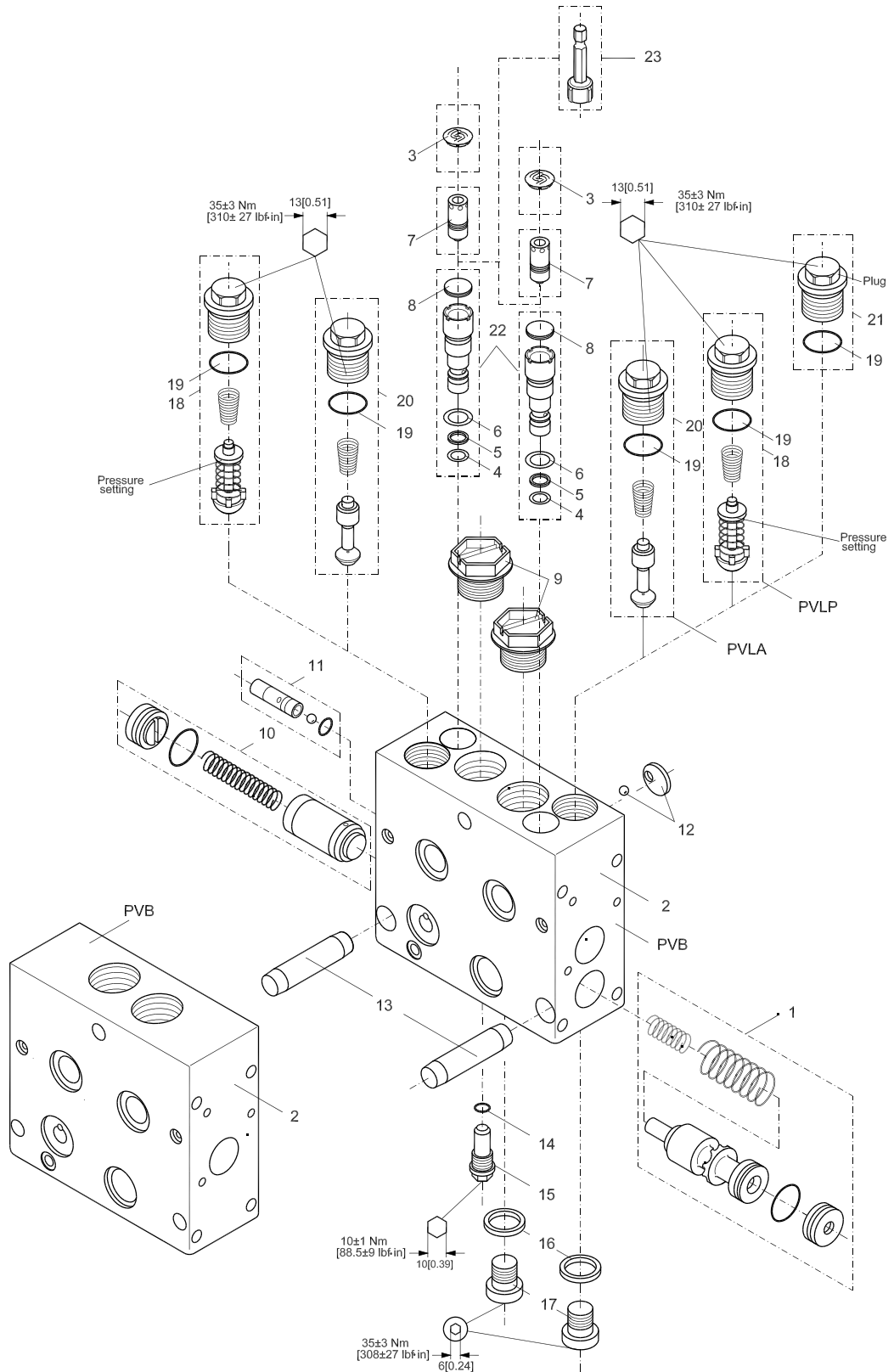

Spare Parts PVB

PVB, Basic Module

Type		Code no.	
		BFP-thread	SAE-thread
PVB	Without compensator / check valve	157B6000	157B6400
PVB	With check valve	157B6100	157B6500
PVB	With compensator valve	157B6200	157B6600
PVB	With compensator valve, LS _{A/B} relief valve and LS _{A/B} shuttle valve	157B6203	157B6603
PVB	With damped compensator valve	157B6206	-
PVB	With damped compensator valve, LS _{A/B} relief valve and LS _{A/B} shuttle valve	157B6208	-
PVB	Without compensator / check valve	157B6030	157B6430
PVB	With check valve	157B6130	157B6530
PVB	With check valve and LS _{A/B} shuttle valve	157B6136	157B6536
PVB	With compensator valve	157B6230	157B6630
PVB	Compensator, LS _{A/B} relief valve and LS _{A/B} shuttle valve	157B6233	157B6633
PVB	With damped compensator valve	157B6236	-
PVB	With damped compensator valve, LS _{A/B} relief valve and LS _{A/B} shuttle valve	157B6238	-

Item	Description													
1	Inlet compensator, assy	1	1	1	1				1	1	1	1		
2	Plastic plug	1	1	1	1	1	1	1	1	1	1	1	1	1
4	Thrust pad Ø8.0 • 1.5 [0.32 • 0.06 in]	2		2					2		2			
5	Back up ring	2		2					2		2			
6	O-ring Ø11.0 • 2.0 [0.43 • 0.08 in]	2		2					2		2			
8*	Plastic plug	2		2					2		2			
9	Plastic plug	G ½ - thread		2	2	2	2	2	2	2	2	2	2	2
		7/8 - 14 UNF-thread				2	2	2	2			2	2	2
10	Check valve assy.						1	1						1
11	Shuttle assy.	1		1			1		1		1			
12	Shuttle assy.	1	1	1	1	1	1	1	1	1	1	1	1	1
13	Pipe	1	1	1	1	1	1	1	1	1	1	1	1	
14*	O-ring Ø6.0 • 1.5 [0.24 • 0.06 in]	1	1						1	1				
15	Damping screw (incl. item 14)	1	1						1	1				
16*	Washer 13.5 • 17.5 • 1.5 [0.53 • 0.69 • 0.06 in]	2		2					2		2			
17	Plug	G ¼ - thread		2		2			2		2			
		½ - 20 UNF-thread				2						2		
19	O-ring Ø15.6 • 1.78 [0.61 • 0.08 in]	1	1	1	1	1	1	1						
*	Set of seals (see page 66)	1	1	1					1	1	1			

PVB, PVLA and PVLP

PVB, Basic Module

PVLA,
Anti-Cavitation Valve

PVLP,
Shock and
Anti-Cavitation Valve

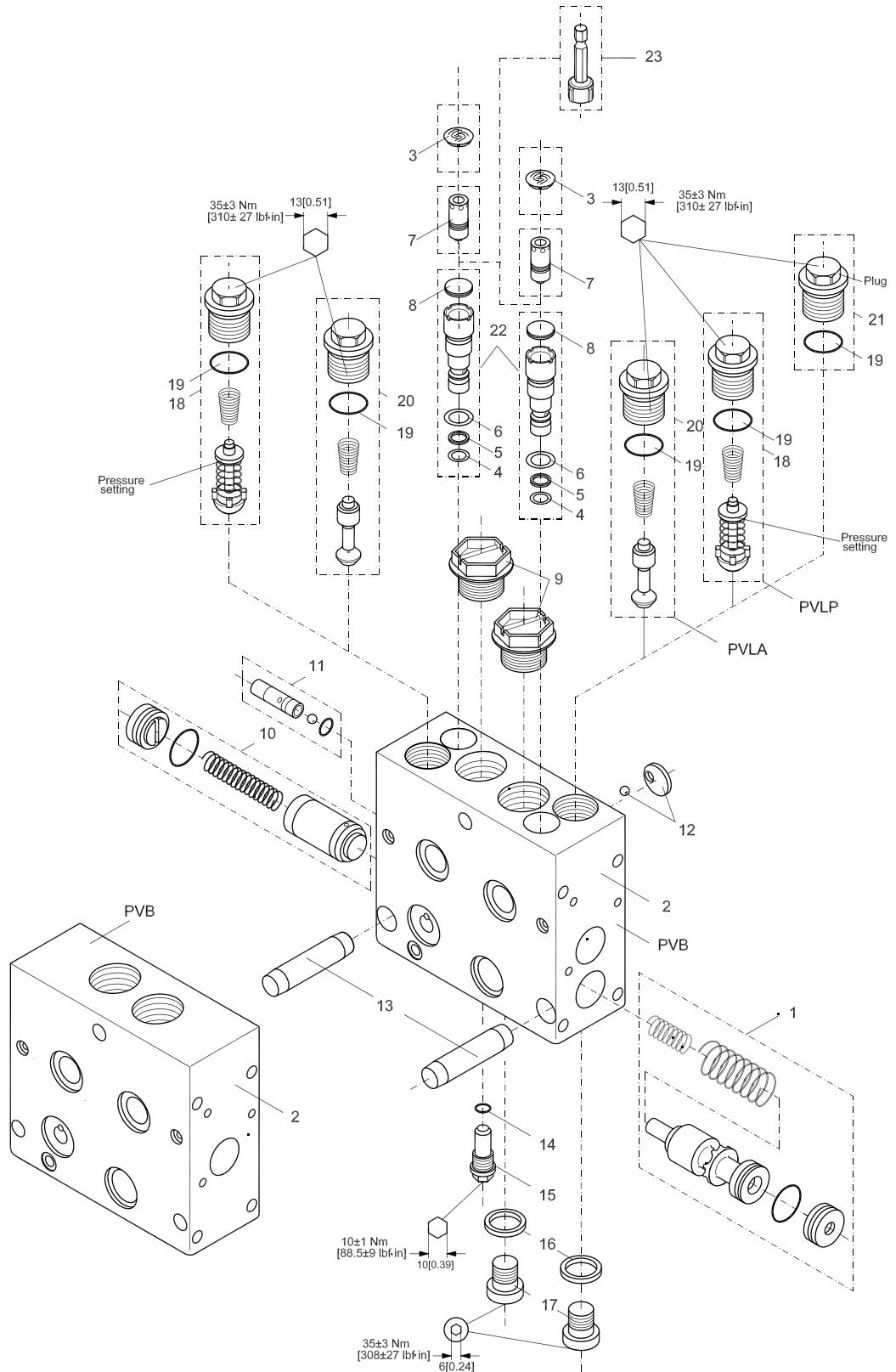

Spare Parts PVLA and PVLP
**PVLA,
Anti-Cavitation Valve**
PVLA, Anti-Cavitation Valve
PVLP, Shock and Anti-Cavitation Valve
**PVLP,
Shock and Anti-Cavitation
Valve**

Item	Description	Code no.
18	PVLP, setting pressure in bar: 32, 50, 63, 100, 125, 140, 150, 160, 175, 190, 210, 230, 240, 250, 265, 280, 300, 320 and 350	157B2....
	PVLP, setting pressure in psi: 464, 725, 914, 1450, 1813, 2030, 2175, 2320, 2538, 2755, 3045, 3335, 3480, 3625, 3443, 4061, 4351, 4641 and 5075	-
20	PVLA valve	157B2001
21	PVLA / PVLP plug (incl. item 19)	157B2002

PVLA and PVLP shall not be used as a pressure relief valve

**Spare Part,
Kits Available**
Spare Part, Kits Available

Item	Description	Code no.
3	Sealed plastic adjustment screw, black (50 pcs.)	155L6168
3	Sealed plastic adjustment screw, yellow (50 pcs.)	155L6167
7	Sealed adjustment screw (for sealing with a wire)	155L6489
22	Relief valve assembly	155L6495
23	Tool for relief valve	155L6494
*	Set of seals (Page 64)	157B6999

PVS and PVSI

PVS/PVSI, End Plate

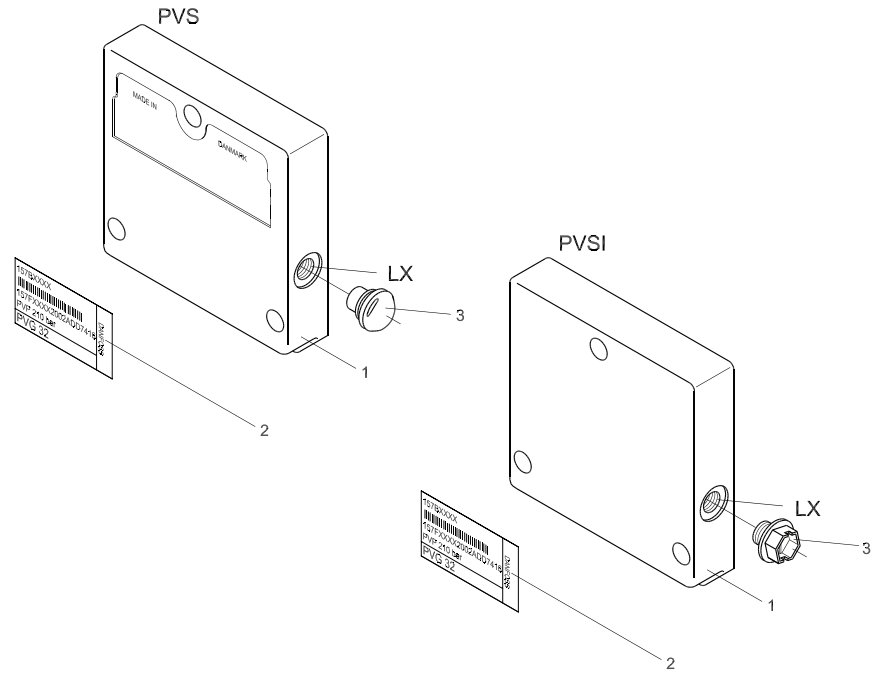

157-106.12

Spare Parts PVS and PVS I

PVS/PVSI, End Plate

Type	Code no.	
	G - thread	UNF-thread
PVS without connection	157B2000	157B2020
PVS with LX connection	157B2011	157B2021
PVS without connection	157B2014	157B2004
PVS with LX connection	157B2015	157B2005

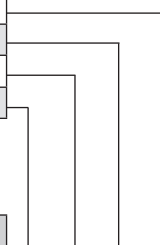

Item	Description					
1	End plate	1	1	1	1	
2	Identification label	1	1	1	1	
3	Plastic plug	G ¹ / ₈ thread			1	
		³ / ₈ - 24 UNF thread			1	
		G ¹ / ₄ thread	1			
		¹ / ₂ - 20 UNF thread	1			

PVAS for PVP

PVAS, Assembly Kit,
PVP

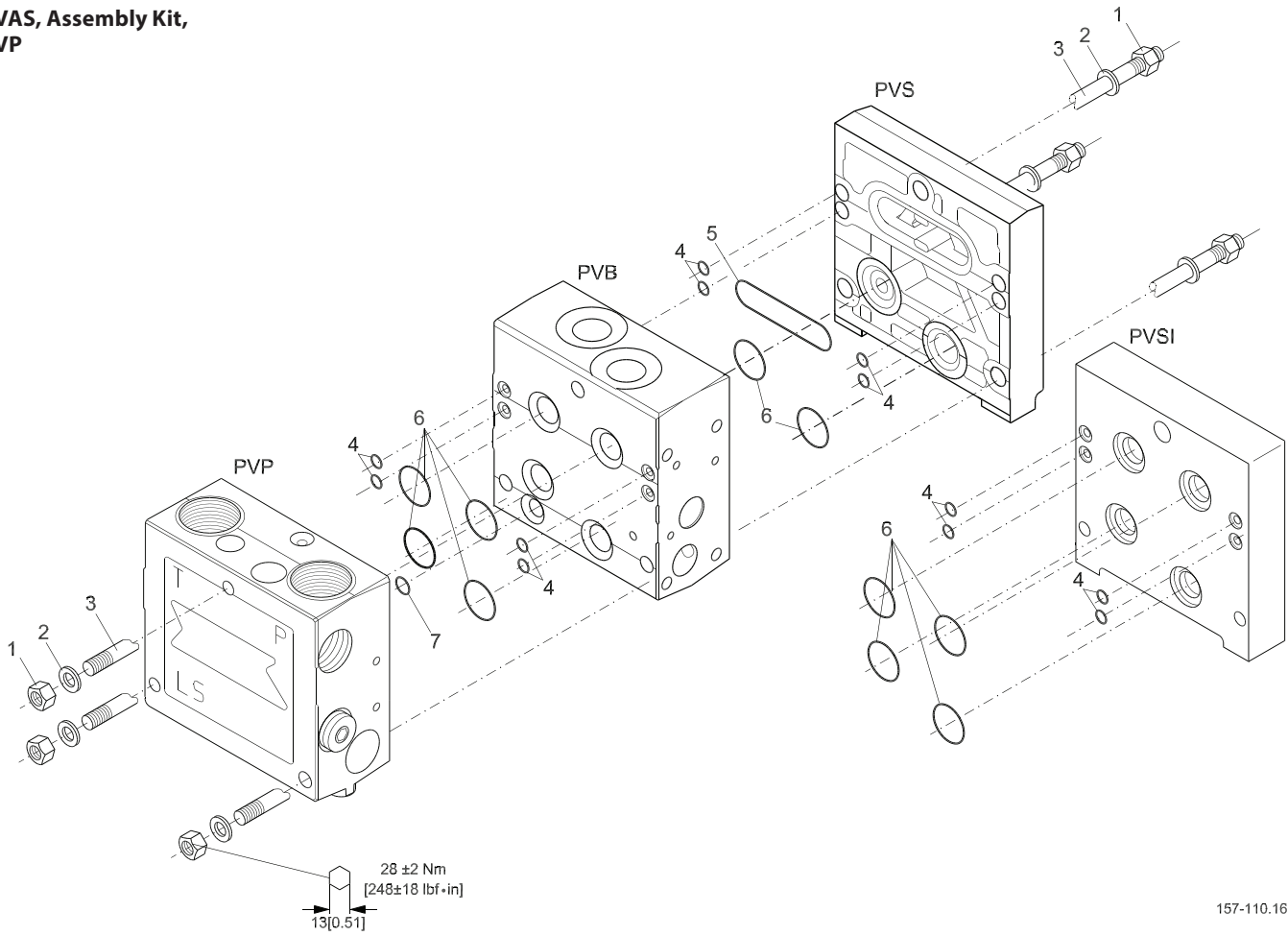

157-110.16

Steel quality	Appearance	Tightening torque
10.9	Yellow zinc chromate surface	28 ± 2 N·m [247.82 ± 17.7 lbf·in]

Spare Parts PVAS for PVP

PVAS, Assembly Kit, PVP

Type		Code no.
PVAS	for 1 PVB on PVGI	157B8000
PVAS	for 1 PVB basic module / for 2 PVB on PVGI	157B8001
PVAS	for 2 PVB basic module / for 3 PVB on PVGI	157B8002
PVAS	for 3 PVB basic module / for 4 PVB on PVGI	157B8003
PVAS	for 4 PVB basic module / for 5 PVB on PVGI	157B8004
PVAS	for 5 PVB basic module / for 6 PVB on PVGI	157B8005
PVAS	for 6 PVB basic module / for 7 PVB on PVGI	157B8006
PVAS	for 7 PVB basic module / for 8 PVB on PVGI	157B8007
PVAS	for 8 PVB basic module	157B8008
PVAS	for 9 PVB basic module	157B8009
PVAS	for 10 PVB basic module	157B8010
PVAS	for 11 PVB basic module	157B8061
PVAS	for 12 PVB basic module	157B8062

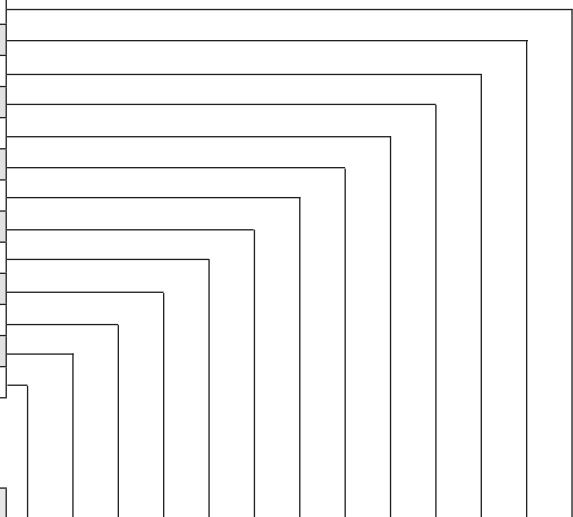

Item	Description	1	2	3	4	5	6	7	8	9	10	11	12	13
1	Nut 8.0	6	6	6	6	6	6	6	6	6	6	6	6	3
2	Washer 8.1 • 15.2 • 1.5 [0.53 • 0.69 • 0.06 in]	6	6	6	6	6	6	6	6	6	6	6	6	3
3	Stay bolt M8; L = 91 [3.58 in]													3
	Stay bolt M8; L = 140 [5.51 in]													3
	Stay bolt M8; L = 189 [7.44 in]												3	
	Stay bolt M8; L = 238 [9.37 in]											3		
	Stay bolt M8; L = 287 [11.30 in]									3				
	Stay bolt M8; L = 336 [13.24 in]								3					
	Stay bolt M8; L = 385 [15.16 in]							3						
	Stay bolt M8; L = 434 [17.07 in]						3							
	Stay bolt M8; L = 483 [19.02 in]					3								
	Stay bolt M8; L = 527 [20.75 in]			3										
	Stay bolt M8; L = 576 [22.68 in]		3											
	Stay bolt M8; L = 625 [24.61 in]	3												
4*	O-ring Ø5.0 • 2.0 [0.20 • 0.08 in]	52	48	44	40	36	36	32	28	24	20	16	12	8
5*	Profile O-ring	1	1	1	1	1	1	1	1	1	1	1	1	1
6*	O-ring Ø16.0 • 2.5 [0.63 • 0.10 in]	56	52	48	44	40	36	32	28	24	20	16	12	8
7*	O-ring Ø10.0 • 2.5 [0.39 • 0.10 in]	12	11	10	9	8	7	6	5	4	3	2	1	1
*	Set of seals (see page 66)	1	1	1	1	1	1	1	1	1	1	1	1	1

* Spare part. Only to be used by change of specification.

PVAS for PVPV/M

PVAS, Assembly Kit
PVPV/M

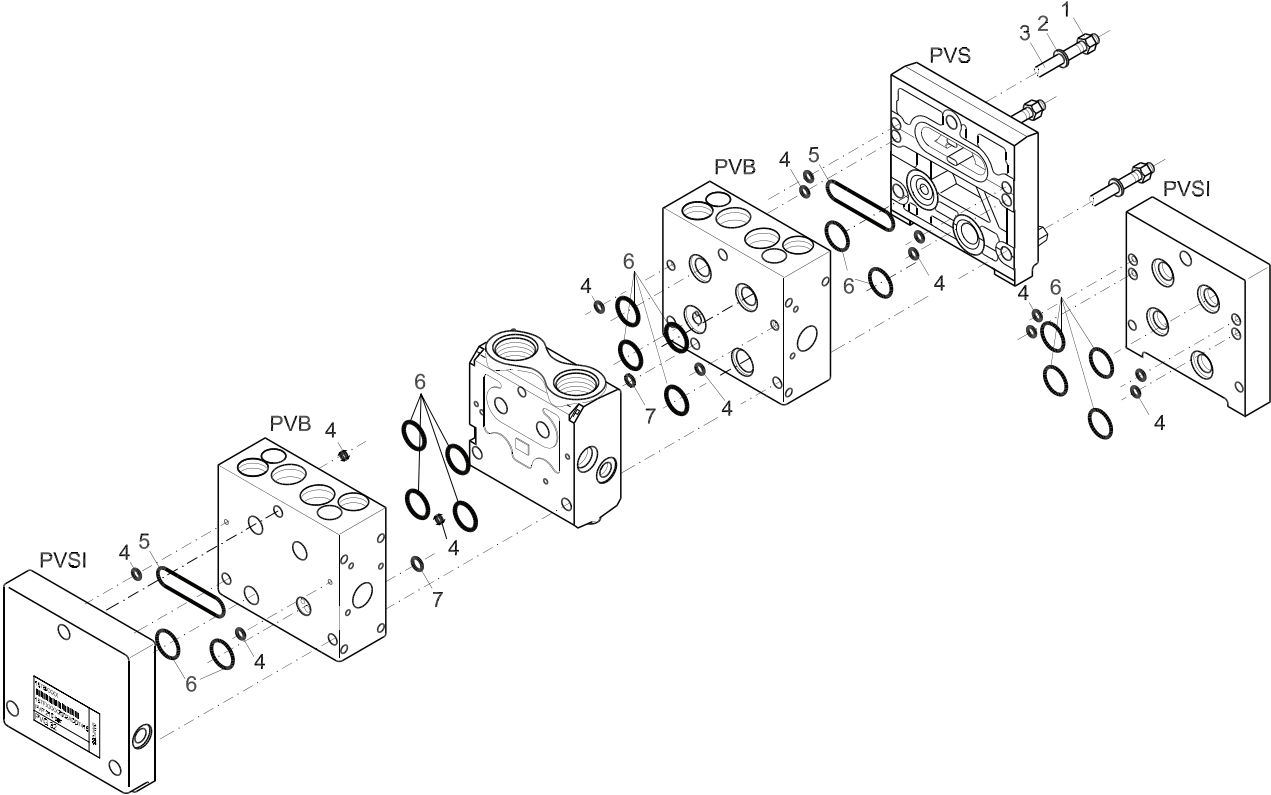

157-436.13

Spare Parts PVAS for PVPV/M

PVAS, Assembly Kit
PVPV/M

Type		Code no.
PVAS	for 1 PVB basic module	157B8021
PVAS	for 2 PVB basic module	157B8022
PVAS	for 3 PVB basic module	157B8023
PVAS	for 4 PVB basic module	157B8024
PVAS	for 5 PVB basic module	157B8025
PVAS	for 6 PVB basic module	157B8026
PVAS	for 7 PVB basic module	157B8027
PVAS	for 8 PVB basic module	157B8028
PVAS	for 9 PVB basic module	157B8029
PVAS	for 10 PVB basic module	157B8030
PVAS	for 11 PVB basis module	157B8081
PVAS	for 12 PVB basis module	157B8082

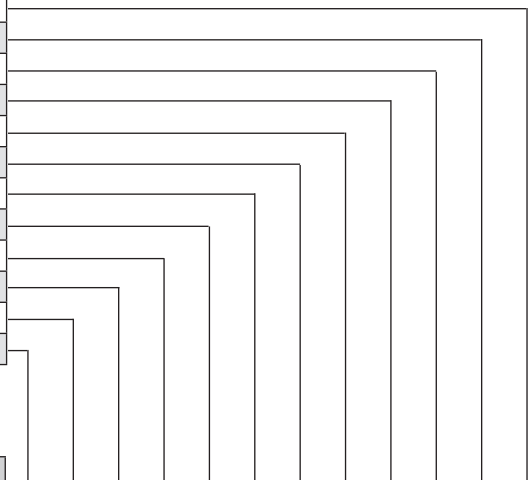

Item	Description	1	2	3	4	5	6	7	8	9	10	11	12
1	Nut 8.0	6	6	6	6	6	6	6	6	6	6	6	6
2	Washer 8.1 • 15.2 • 1.5 [0.53 • 0.69 • 0.06 in]	6	6	6	6	6	6	6	6	6	6	6	6
3	Stay bolt M8; L = 166 [6.54 in]												3
	Stay bolt M8; L = 213 [8.39 in]												3
	Stay bolt M8; L = 262 [10.31 in]											3	
	Stay bolt M8; L = 311 [12.20 in]										3		
	Stay bolt M8; L = 360 [14.17 in]									3			
	Stay bolt M8; L = 409 [16.10 in]								3				
	Stay bolt M8; L = 458 [17.95 in]								3				
	Stay bolt M8; L = 507 [19.96 in]						3						
	Stay bolt M8; L = 551 [22.00 in]				3								
	Stay bolt M8; L = 600 [23.62 in]			3									
	Stay bolt M8; L = 649 [24.61 in]		3										
	Stay bolt M8; L = 698 [26.54 in]	3											
4*	O-ring Ø5.0 • 2.0 [0.20 • 0.08 in]	56	52	48	44	40	36	32	28	24	20	16	12
5*	Profile O-ring	2	2	2	2	2	2	2	2	2	2	2	2
6*	O-ring Ø16.0 • 2.5 [0.63 • 0.10 in]	56	52	48	44	40	36	32	28	24	20	16	12
7*	O-ring Ø10.0 • 2.5 [0.39 • 0.10 in]	12	11	12	11	10	9	8	7	6	5	4	1
*	Set of seals (see page 66)	1	1	1	1	1	1	1	1	1	1	1	1

VVPX and PVPC

VVPX,
LS Unloading Valve

PVPC, Plug for External Pilot
Oil Supply

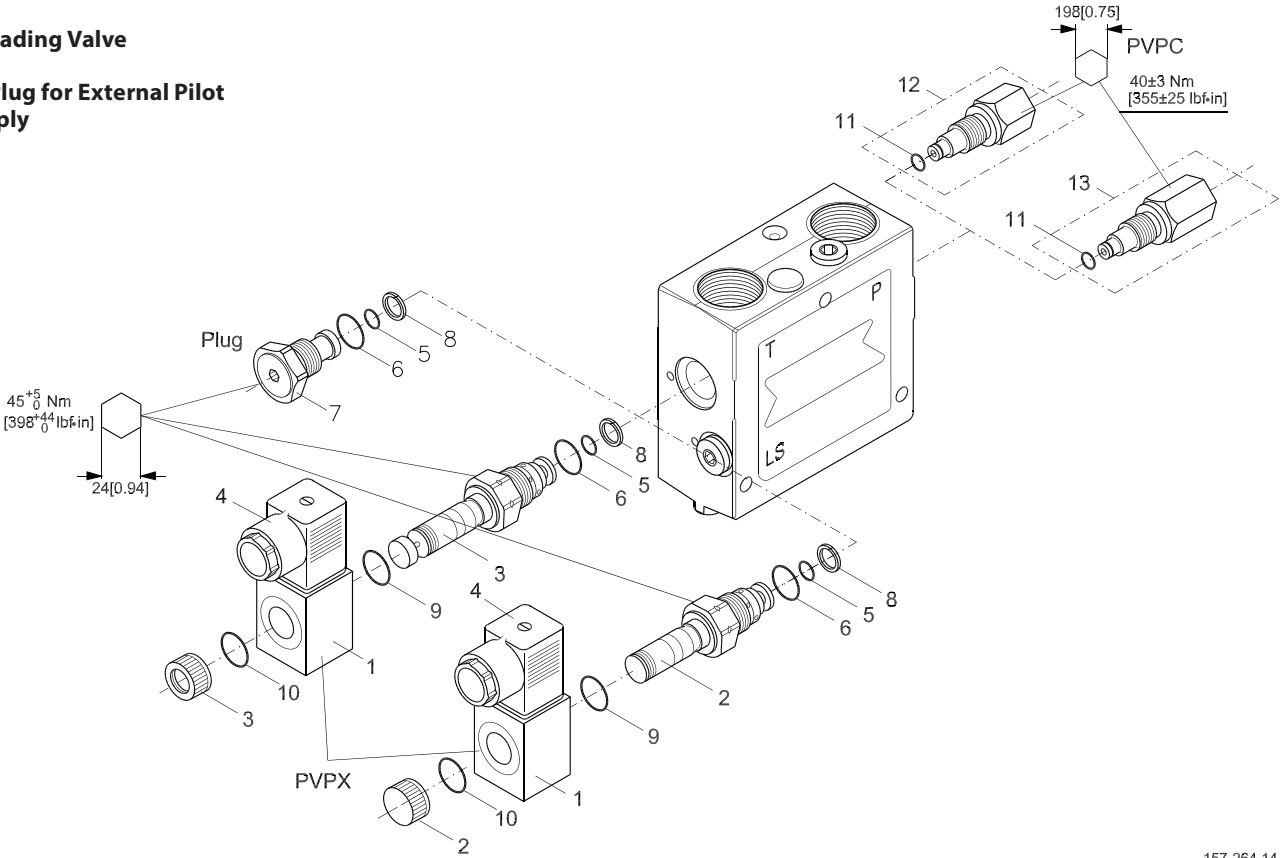

157-264.14

Spare Parts PVPX and PVPC
PVPX, LS Unloading Valve

Type		Code no.	
		12 VDC	24 VDC
PVPX	Normally open	157B4236	157B4238
PVPX	Normally closed	157B4246	157B4248
PVPX	Normally open with manual override	157B4256	157B4258
PVPX	Normally open with manual override (26 Volt)	-	157B4260
	Plug	157B5601	

Item	Description						
1	PVPX	Coil 12 Volt			1	1	1
	PVPX	Coil 24 Volt			1	1	1
	PVPX	Coil 12 Volt (before 1996 incl. item 9)			1	1	1
	PVPX	Coil 24 Volt (before 1996 incl. item 9)		1	1	1	1
	PVPX	Coil 26 Volt (incl. item 9)		1			
2	PVPX (incl. 5, 6, 8, 9)	Solenoid valve NO					1
	PVPX (incl. 5, 6, 8, 9)	Solenoid valve NC				1	
3	PVPX (incl. 5, 6, 8, 9)	Solenoid valve NO with manual override		1	1		
4	PVPX el-plug			1	1	1	1
5*	O-ring	Ø9.25 • 1.78 [0.36 • 0.07 in]	1	1	1	1	1
6*	O-ring	Ø16.36 • 2.21 [0.64 • 0.08 in]	1	1	1	1	1
7	PVPX plug		1				
8*	Backup-ring 12.7 [0.50]		1	1	1	1	1
9*	O-ring	Ø12,5 • 1.8 [0.49 • 0.07 in]		1	1	1	1
10	O-ring Ø14 • 1.78 [0.55 • 0.07 in]			1	1	1	1
*	Set of seals (see page 66)						

PVPC, Plug for external pilot oil supply

Type		Code no.	
		BSP - thread	SAE-thread
PVPC	External pilot supply	157B5400	-
PVPC	External pilot supply incl. check valve	157B5600	157B5700

Item	Description			
11	O-ring	Ø5.0 • 1.0 [20 • 0.04 in]	1	1
12	PVPC external pilot supply	G¼ - thread		1
13	PVPC external pilot supply incl. check valve		1	
		½ - 20 UNF - thread	1	

PVBS

PVBS, Main Spool

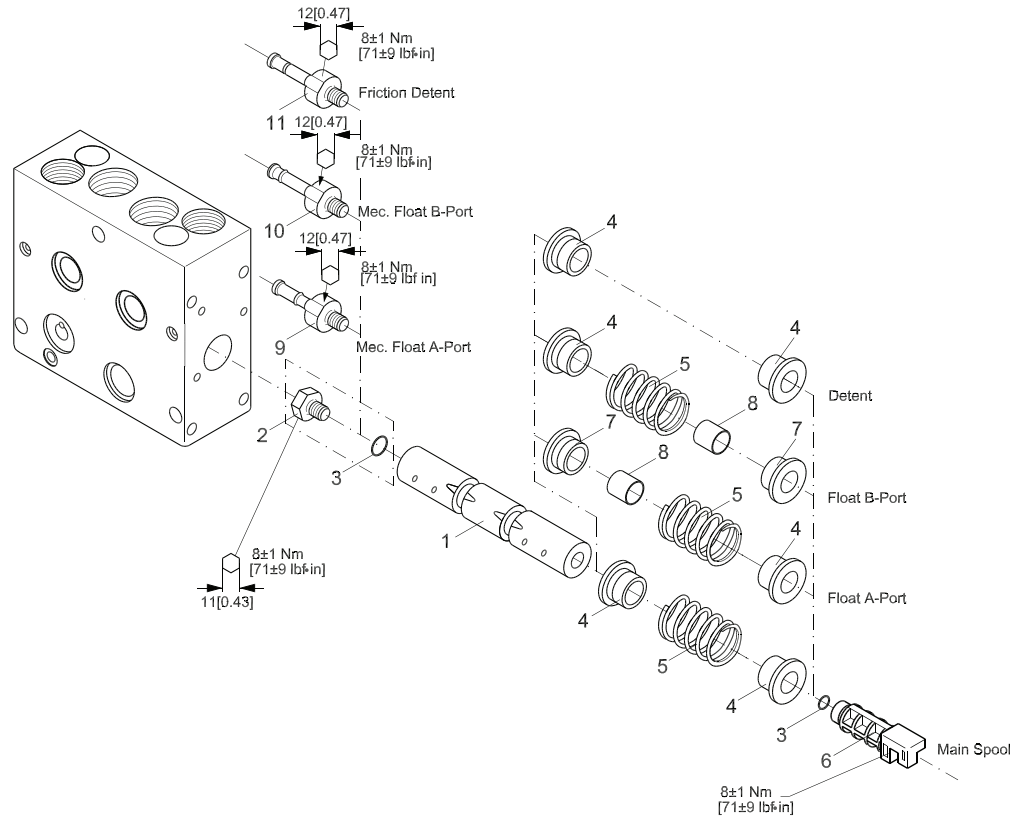

157-112.13

Spare Parts PVBS
PVBS, Main Spool

Type					
PVBS	Standard				
PVBS	Elec. float position B-port				
PVBS	Elec. float position A-port				
PVBS	Mec. float position B-port				
PVBS	Friction detent				

Item	Description					
1	Main spool	1	1	1	1	1
2	Plug				1	1
3	O-ring $\varnothing 6.0 \cdot 1.5$ [0.24 • 0.06 in]	2	2	2	2	2
4	Spring stop	2	1	1	1	2
5	Spring		1	1	1	1
	Spring hydraulic actuation					1
6	Tension rod	1	1	1	1	1
7	Spring stop (float position)		1	1	1	
8	Bushing [float position]		1	1	1	
9	Float position A-port (incl.item 3)			1		
10	Float position B-port (incl.item 3)		1			
11	Friction detent (incl. item 3)	1				

Spare Part, Kits Available

Item	Description	Code no.
5	Hydraulic spring	155L7504
9	Float position A-port (incl.item 3)	155L9151
10	Float position B-port (incl.item 3)	155L9152
11	Friction detent (incl. item 3)	155L9150

PVM

PVM,
Mechanical Activation

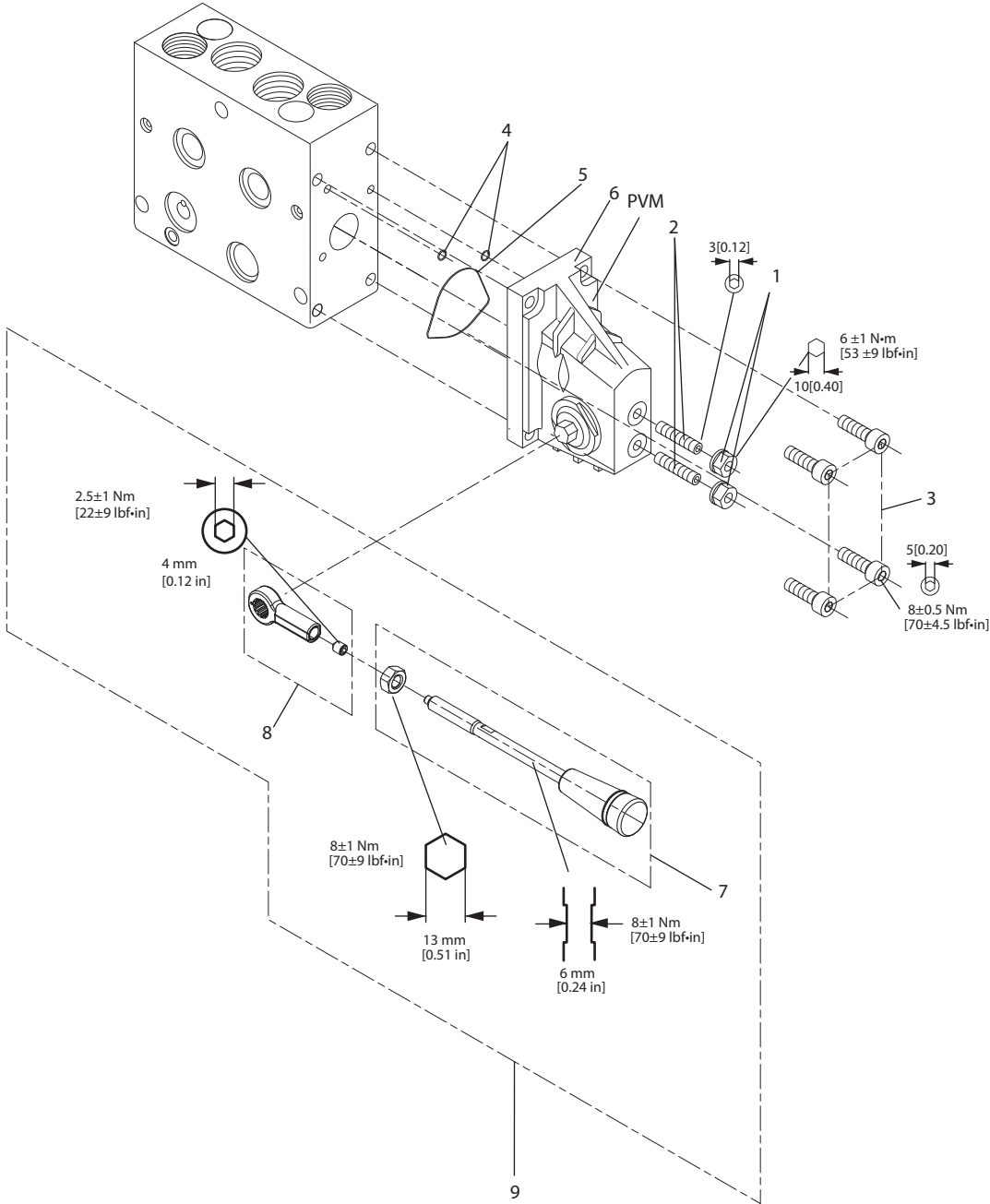

V310172.B

Spare Parts PVM
PVM, Mechanical Activation

Type		Code no.			
		With stop screw			Without stop screw
		Standard	Anodized	Cast iron	Standard
PVM, with handle and base	22.5°/37.5°	157B3171	157B3184	157B3161	157B3191
PVM, without handle and base	-	157B3173	-	157B3163	157B3193
PVM, with base	22.5°/37.5°	157B3174	-	157B3164	157B3194

Item	Description			
1	Seal nut			
2	Threaded pin			
3	Screw	4	4	4
4*	O-ring 5.0 • 2.0 [0.2 • 0.08 in]	2	2	2
5*	Profile O-ring	1	1	
6	Housing	1	1	1
7	Handle, black knob, including nut			
8	Base, including set screw		22.5°/37.5°	1
9	Lever, with black knob handle and base (7 & 8)			1

Spare Part, Kits Available

Item	Description	Code no.
	Lever, with black knob handle and base	11046724
*	Set of seals (see page 64)	157B3999
	Lever, with red knob handle and base	11064640
7	Handle with black knob and nut	11077262
8	Base, including set screw	11064641

PVMD; Cover for Mechanical Activation

PVM, Mechanical Activation

PVH, Hydraulic Activation

PVMR, Mechanical Detent

PVMF, Mechanical Float

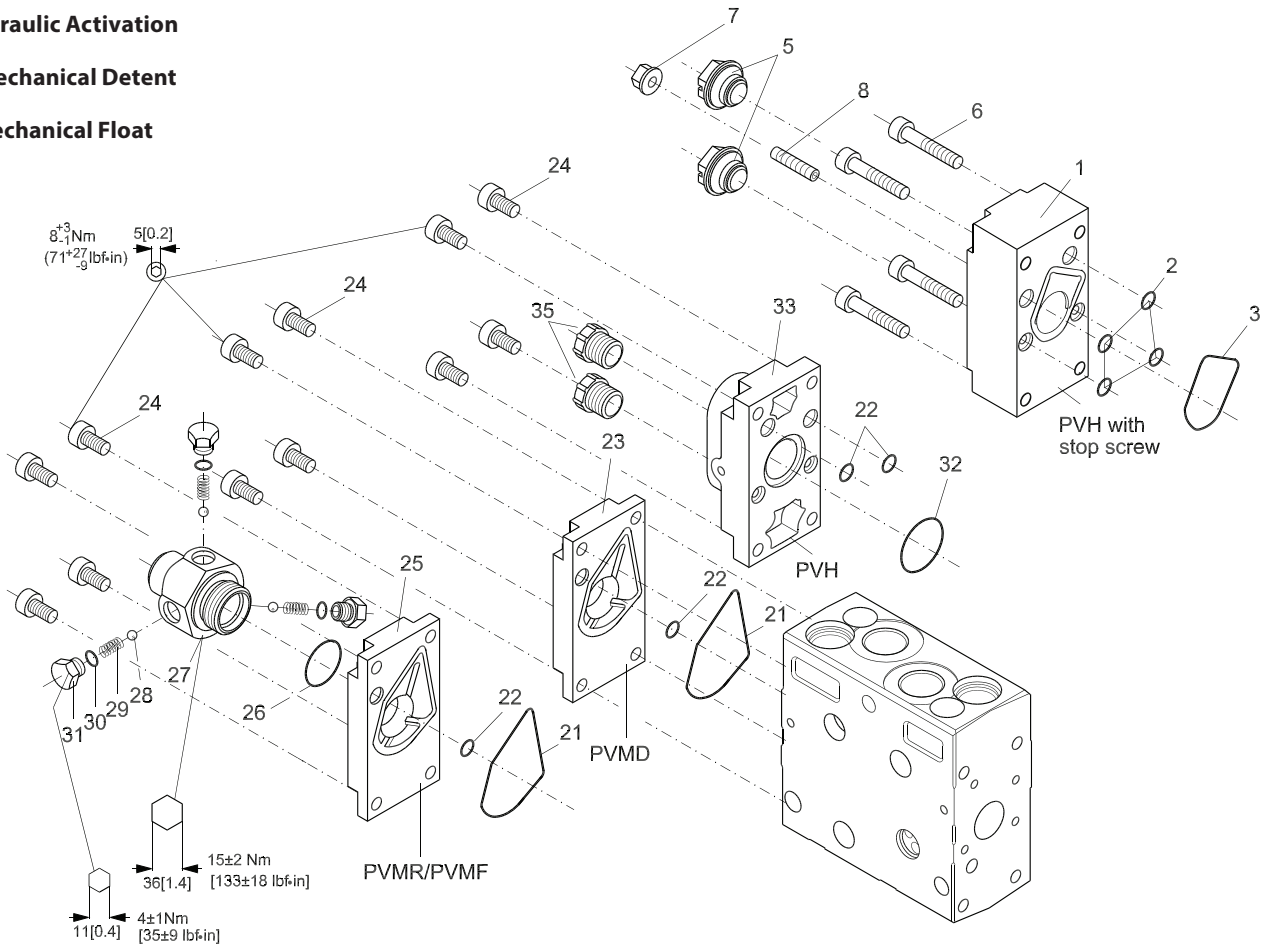

157-265.13

Spare Parts PVMD; Cover for Mechanical Activation
PVMD, Cover for, Mechanical Activation
PVH, Hydraulic Activation
PVMR, Mechanical Detent
PVMF, Mechanical Float

Type		Code no.	
PVH	Hydraulic activation, with stop screw	G 1/4 thread	157B0016
		9/16 - 18 UNF	157B0014
PVH	Hydraulic activation	G 1/4 thread	157B0008
		9/16 - 18 UNF	157B0007
PVMR	Friction detent	157B0004	
PVMF	Mechanical float position	157B0005	
PVMD		157B0001	

Item	Description					
1	Cover					1
2	O-ring $\varnothing 5.0 \cdot 2.0$ [0.197 • 0.079 in]				4	4
3	O-ring $\varnothing 30.0 \cdot 2.5$ [1.18 • 0.99 in]				1	1
5	Threaded plug with O-ring				1	1
6	Screw				4	4
7	Nut				1	1
8	Screw				1	1
21*	Profile O-ring	1	1	1		
22*	O-ring $\varnothing 5.0 \cdot 2.0$ [0.2 • 0.08 in]	1	1	1	4	4
23	Cover	1				
24	Screw M6; L = 15 [0.59 in]	4	4	4	4	4
25	Cover		1	1		
26*	O-ring $\varnothing 19.3 \cdot 2.4$ [0.76 • 0.09 in]		1	1		
27	Plug		1	1		
28	Ball $\varnothing 5$ [0.5 in]		3	3		
29	Spring		3			
29	Spring			3		
30*	O-ring $\varnothing 6.0 \cdot 1.5$ [0.24 • 0.59 in]		3	3		
31	Plug		3	3		
32*	O-ring $\varnothing 21.3 \cdot 2.4$ [0.84 • 0.09 in]				1	1
33	Cover	G - thread			1	1
		UNF - thread			1	1
35	Sealing plug	G - thread			2	2
		UNF - thread			2	2
*	Set of seals (see page 66)	1	1	1	1	1

Spare Part, Kits Available

Item	Description	Code no.
*	Set of seals (Page 66)	157B6999

PVHC

Electrical Activation PVHC

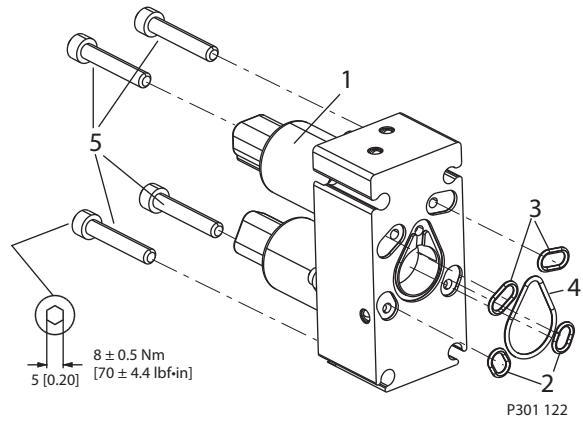

Spare Parts PVHC
Electrical Activation PVHC

Type		Code no.				
PVHC	AMP Connector, 12 V	11061228				
	AMP Connector, 24 V	11061227				
	Deutsch Connector, 12 V	11061229				
	Deutsch Connector, 24 V	11061230				

Item	Description				
1	Solenoid valve, 12 V - AMP Connector				2
	Solenoid valve, 24 V - AMP Connector			2	
	Solenoid valve, 12 V - Deutsch Connector		2		
	Solenoid valve, 24 V - Deutsch Connector	2			
2*	O-ring $\varnothing 8.0 \cdot 2.0$ [0.31 • 0.08 in]	2	2	2	2
3*	O-ring $\varnothing 10.0 \cdot 2.0$ [0.39 • 0.08 in]	2	2	2	2
4*	O-ring $\varnothing 21.20 \cdot 2.4$ [0.83 • 0.09 in]	1	1	1	1
5*	Screws M6 x 35	4	4	4	4
*	Set of seals (see page 66)	1	1	1	1

Spare Part, Kits Available

Item	Description	Code no.
1	Solenoid valve, 12 V - AMP Connector	11061232
	Solenoid valve, 24 V - AMP Connector	11061231
	Solenoid valve, 12 V - Deutsch Connector	11061233
	Solenoid valve, 24 V - Deutsch Connector	11061234
*	Set of seals (see page 66)	11061235

Electrical Actuation with AMP-Connector

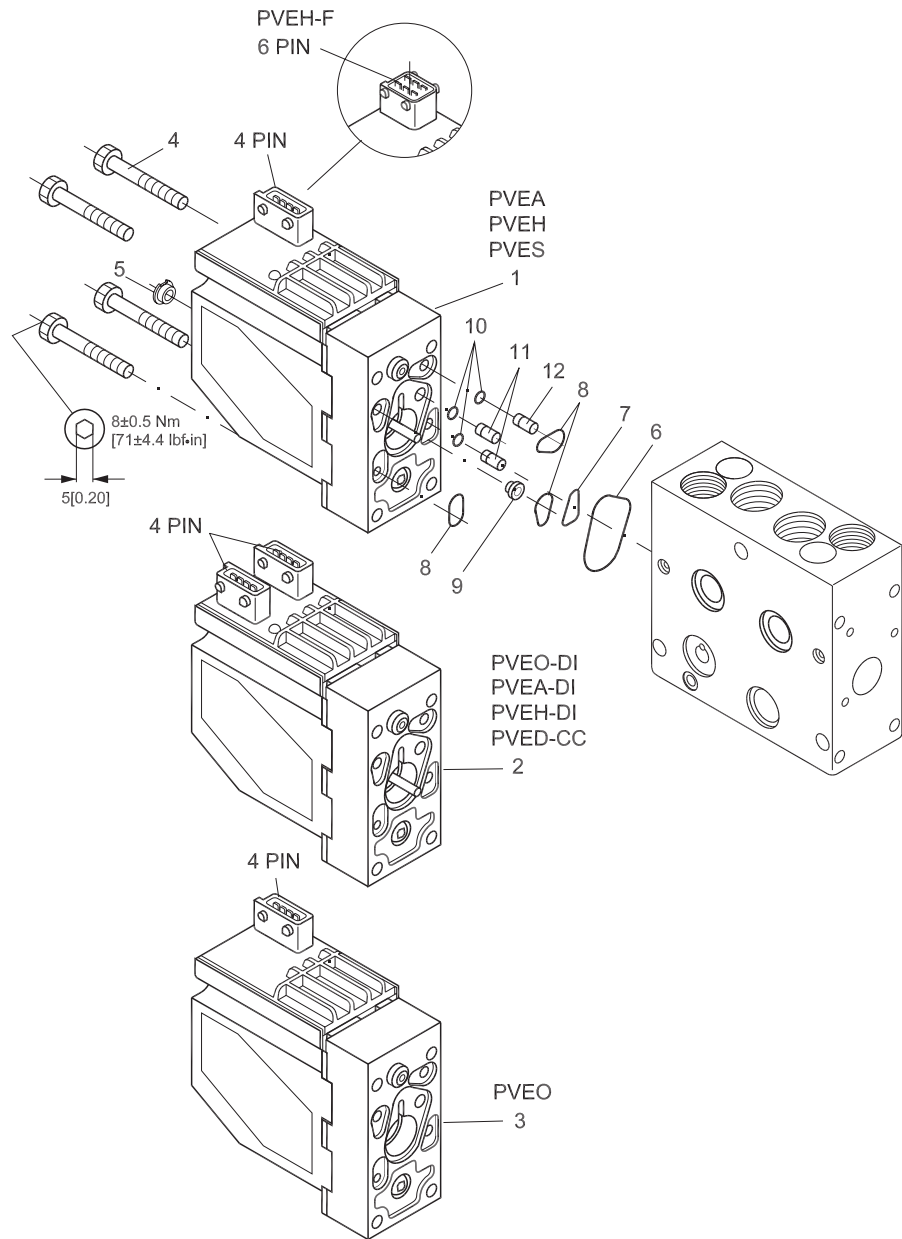

157-781.11

Electrical Actuation with AMP-Connector

Electrical Actuation with AMP-Connector

Type		AMP-connector	
		12 V	24 V
PVEO	ON/OFF	157B4901	157B4902
PVEO	ON/OFF with ramp	157B4903	157B4904
PVEO-DI	PVEO-DI	157B4905	157B4906

11 - 32 V		
PVEA	Standard, active	157B4734
	Standard, passive	157B4735
PVEA-DI	Standard, active	157B4736
	Standard, passive	157B4737
PVEH	Standard, active	157B4034
	Standard, passive	157B4035
PVEH-F	Float, active fault monitoring	157B4338
PVEH-DI	Standard, active	157B4036
	Standard, passive	157B4037
PVES	0% hysteresis, active fault monitoring	157B4834
	0% hysteresis, passive fault monitoring	157B4835
PVEP		-
PVEP-F		-
PVED-CC	CAN-bus	157B4943

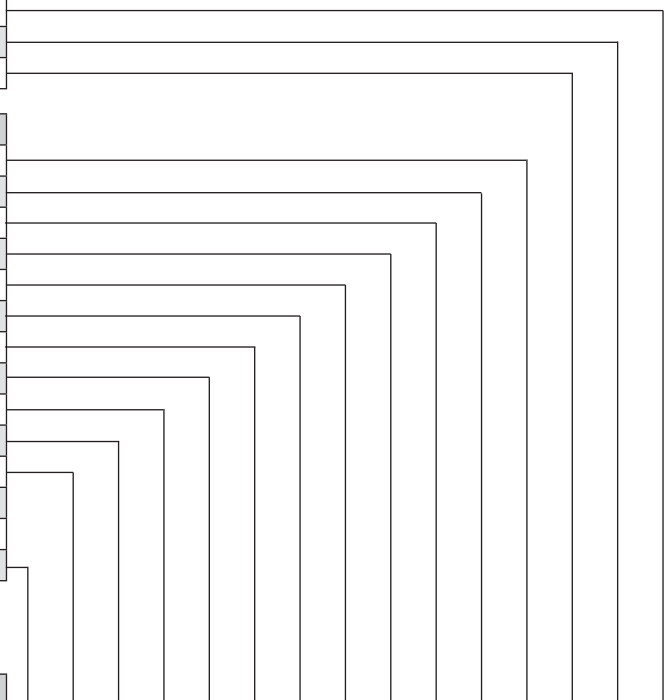

Item	Description																			
1	PVES assembly		1	1																
1	PVEH assembly				1	1	1	1												
1	PVEA assembly											1	1							
2	PVEA-DI assembly										1	1								
2	PVED-CC assembly	1																		
3	PVEO assembly																1	1	1	
4	Screw M6; L = 33 [1.30 in]	4	4	4	4	4	4	4	4	4	4	4	4	4	4	4	4	4	4	4
5	Plug	1	1	1	1	1	1	1	1	1	1	1	1	1	1	1				
6*	O-ring \varnothing 30.0 • 2.5 [1.18 • 0.99 in]	1	1	1	1	1	1	1	1	1	1	1	1	1	1	1	1	1	1	1
7*	O-ring \varnothing 8.0 • 2.0 [0.32 • 0.08 in]	1	1	1	1	1	1	1	1	1	1	1	1	1	1	1	1	1	1	1
8*	O-ring \varnothing 10.0 • 2.0 [0.39 • 0.08 in]	3	3	3	3	3	3	3	3	3	3	3	3	3	3	3	3	3	3	3
9	Filter	1	1	1	1	1	1	1	1	1	1	1	1	1	1	1	1	1	1	1
10*	O-ring \varnothing 4.0 • 1.0 [0.16 • 0.04 in]	3	3	3	3	3	3	3	3	3	3	3	3	3	3	3	3	3	3	3
	O-ring \varnothing 3.0 • 1.5 [0.12 • 0.06 in]	3	3	3	3	3	3	3	3	3	3	3	3	3	3	3	3	3	3	3
11	Check valve	2	2	2	2	2	2	2	2								2	2	2	
	Orifice \varnothing 0.6*											2	2	2	2					
12	Orifice \varnothing 1.0	1	1	1	1	1	1	1	1											
	Orifice \varnothing 0.5																	1	1	
	Orifice \varnothing 0.8																			1
	Check valve											1	1	1	1					
*	Set of seals 157B4997 (see page 66)	1	1	1	1	1	1	1	1	1	1	1	1	1	1	1	1	1	1	1

Electrical Actuation with
Hirschmann-Connector

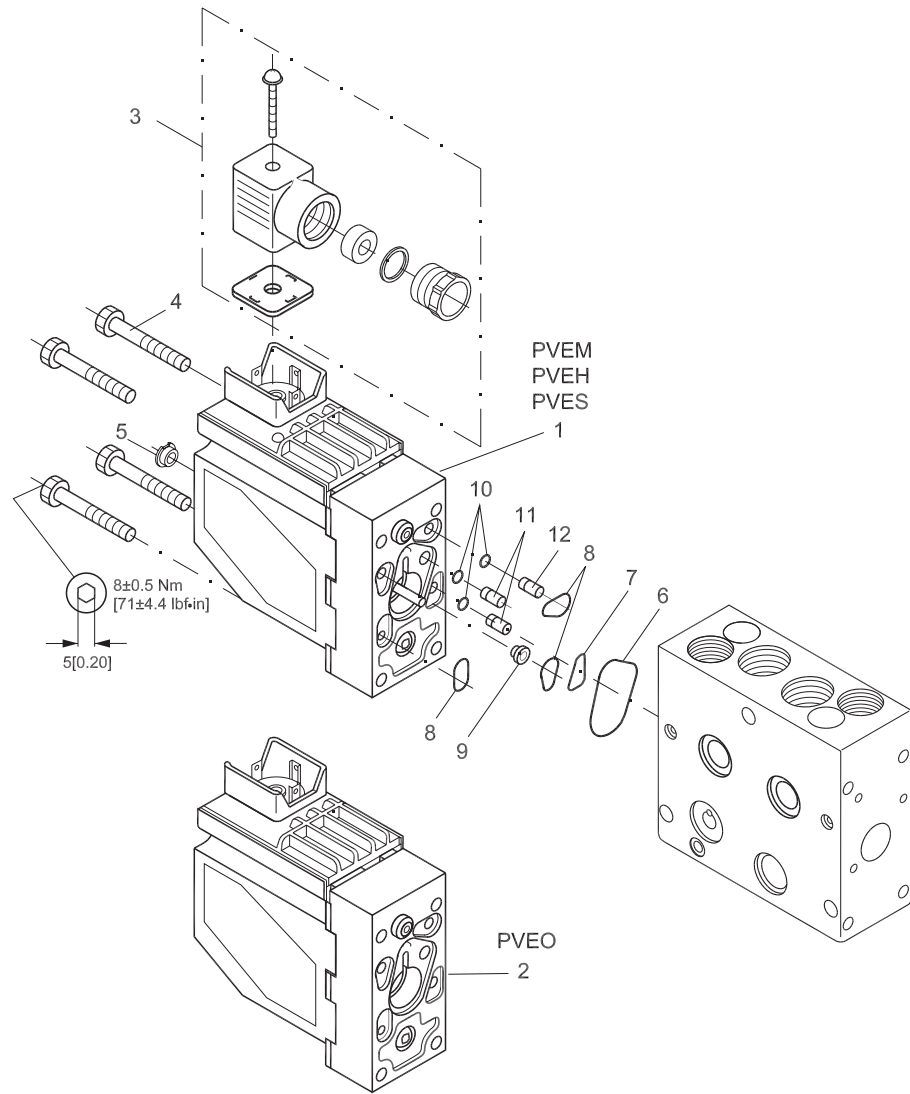

157-780.11

Electrical Actuation with Hirschmann-Connector

Electrical actuation with Hirschmann-connector

Type		Hirschmann-connector	
		12 V	24 V
PVEO	ON/OFF	157B4216	157B4228
PVEO	ON/OFF with ramp	157B4217	157B4229
PVEM	Standard	157B4116	157B4128
	Float	157B4416	157B4428

		11 - 32 V
PVEA	Standard, active	-
	Standard, passive	-
PVEA-DI	Standard, active	-
	Standard, passive	-
PVEH	Standard, active	157B4032
	Standard, passive	157B4033
	Float, active fault monitoring	157B4332
PVEH-DI	Standard, active	-
	Standard, passive	-
PVES	0% hysteresis, activ fault monitoring	157B4832
	0% hysteresis, passive fault monitoring	157B4833
PVEP	PVM, standard	-
PVEP-F	PVM, float	-
PVED-CC	Canbus	-

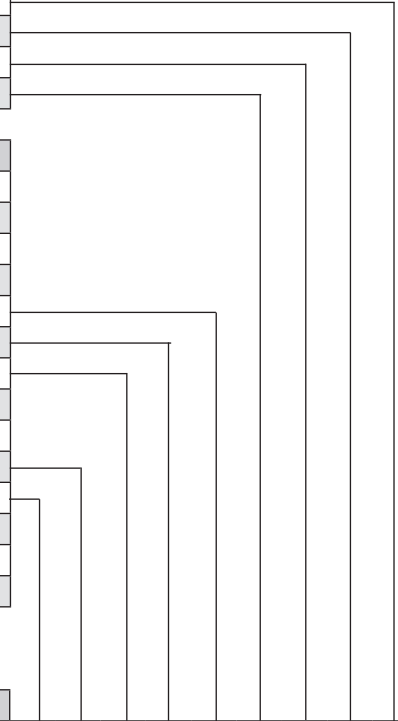

Item	Description	1	2	3	4	5	6	7	8	9	10	11	12
1	PVES assembly	1	1										
1	PVEH assembly			1	1	1							
1	PVEM assembly						1	1					
2	PVEO assembly								1	1			
3	El-plug, DIN43650	1	1	1	1	1	1	1	1	1	1	1	1
4	Screw M6; L = 33 [1.30 in]	4	4	4	4	4	4	4	4	4	4	4	4
5	Plug	1	1	1	1	1	1	1	1				
6*	O-ring Ø30.0 • 2.5 [1.18 • 0.99 in]	1	1	1	1	1	1	1	1	1	1	1	1
7*	O-ring Ø8.0 • 2.0 [0.32 • 0.08 in]	1	1	1	1	1	1	1	1	1	1	1	1
8*	O-ring Ø10.0 • 2.0 [0.39 • 0.08 in]	3	3	3	3	3	3	3	3	3	3	3	3
9	Filter	1	1	1	1	1	1	1	1	1	1	1	1
10*	O-ring Ø4.0 • 1.0 [0.16 • 0.04 in]	3	3	3	3	3	3	3	3	3	3	3	3
	O-ring Ø3.0 • 1.5 [0.12 • 0.06 in]	3	3	3	3	3	3	3	3	3	3	3	3
11	Check valve	2	2	2	2	2	2	2	2	2	2	2	2
12	Orifice Ø1.0	1	1	1	1	1	1	1	1				
	Orifice Ø0.5												
	Orifice Ø0.8											1	1
*	Set of seals 157B4997 (see page 66)	1	1	1	1	1	1	1	1	1	1	1	1

Electrical Actuation with Deutsch-Connector

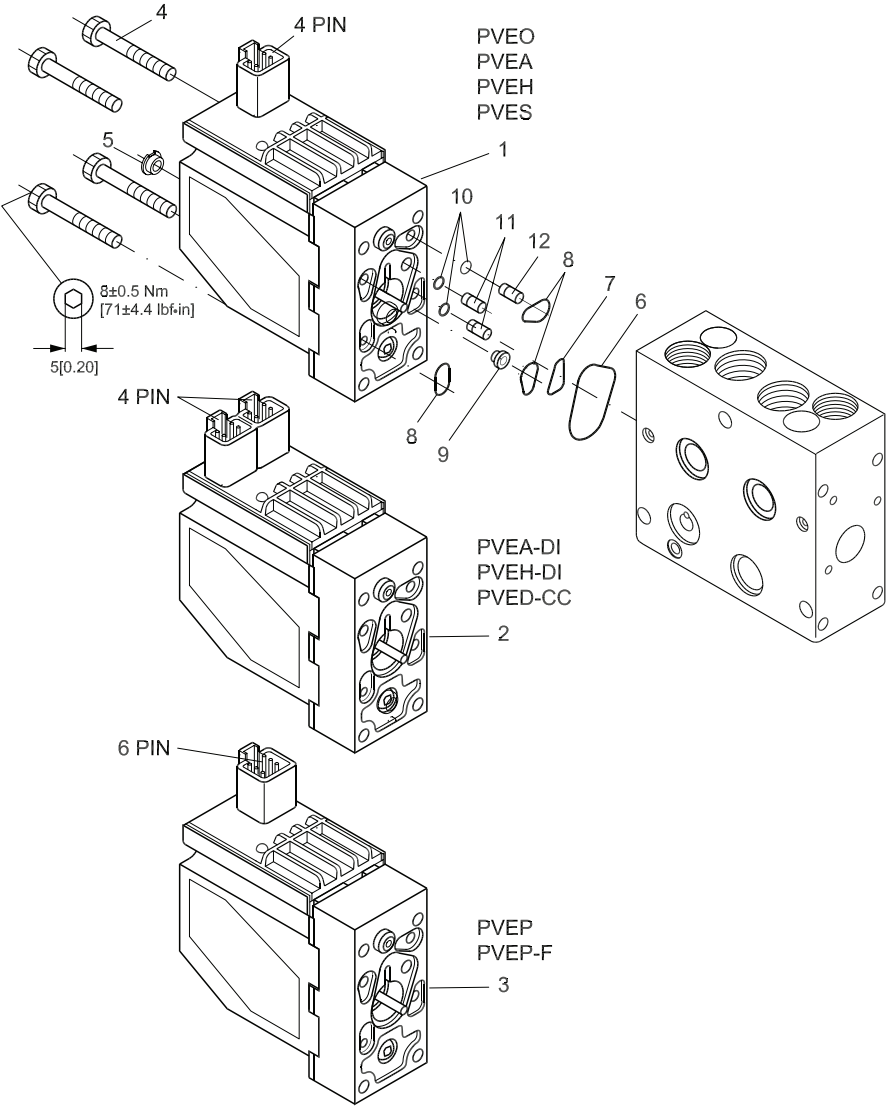

157-782.10

Electrical Actuation with Deutsch-Connector

Electrical Actuation with Deutsch-Connector

Type		Deutsch-connector	
		12 V	24 V
PVEO	ON/OFF	157B4291	157B4292
PVEO	ON/OFF with ramp	-	-
PVEM	Standard	-	-
	Float	-	-

11 - 32 V		
PVEA	Standard, active	157B4792
	Standard, passive	-
PVEA-DI	Standard, active	157B4796
	Standard, passive	-
PVEH	Standard, active	157B4092
	Standard, passive	-
	Float, active fault monitoring	157B4398
PVEH-DI	Standard, active	157B4096
	Standard, passive	-
PVES	0% hysteresis, activ fault monitoring	157B4892
	0% hysteresis, passive fault monitoring	-
PVEP	PVM, standard	11034832
PVEP-F	PVM, float	157B4753
PVED-CC	Canbus	157B4944

Item	Description																			
1	PVES assembly					1														
1	PVEH assembly									1	1									
1	PVEA assembly																		1	
1	PVEO assembly																			1
2	PVEA-DI assembly																	1		
2	PVEH-DI assembly								1											
2	PVED-CC assembly	1																		
3	PVEP assembly					1														
3	PVEP-F assembly					1														
4	Screw M6; L = 33 [1.30 in]	4	4	4	4	4	4	4	4	4	4	4	4	4	4	4	4	4	4	4
5	Plug	1	1	1	1	1	1	1	1	1	1	1	1	1	1	1	1	1	1	1
6*	O-ring Ø30.0 • 2.5 [1.18 • 0.99 in]	1	1	1	1	1	1	1	1	1	1	1	1	1	1	1	1	1	1	1
7*	O-ring Ø8.0 • 2.0 [0.32 • 0.08 in]	1	1	1	1	1	1	1	1	1	1	1	1	1	1	1	1	1	1	1
8*	O-ring Ø10.0 • 2.0 [0.39 • 0.08 in]	3	3	3	3	3	3	3	3	3	3	3	3	3	3	3	3	3	3	3
9	Filter	1	1	1	1	1	1	1	1	1	1	1	1	1	1	1	1	1	1	1
10*	O-ring Ø4.0 • 1.0 [0.16 • 0.04 in]	3	3	3	3	3	3	3	3	3	3	3	3	3	3	3	3	3	3	3
	O-ring Ø3.0 • 1.5 [0.12 • 0.06 in]	3	3	3	3	3	3	3	3	3	3	3	3	3	3	3	3	3	3	3
11	Check valve	2	2	2	2	2	2	2	2	2	2	2	2	2	2	2	2	2	2	2
	Orifice Ø0.6*																	2	2	
12	Orifice Ø1.0	1	1	1	1	1	1	1	1	1	1	1	1	1	1	1	1	1	1	1
	Orifice Ø0.5																			
	Orifice Ø0.8																			1
	Check valve																		1	1
*	Set of seals 157B4997 (see page 66)	1	1	1	1	1	1	1	1	1	1	1	1	1	1	1	1	1	1	1

Notes



Products we offer:

- Bent Axis Motors
- Closed Circuit Axial Piston Pumps and Motors
- Displays
- Electrohydraulic Power Steering
- Electrohydraulics
- Hydraulic Power Steering
- Integrated Systems
- Joysticks and Control Handles
- Microcontrollers and Software
- Open Circuit Axial Piston Pumps
- Orbital Motors
- PLUS+1® GUIDE
- Proportional Valves
- Sensors
- Steering
- Transit Mixer Drives

Danfoss Power Solutions is a global manufacturer and supplier of high-quality hydraulic and electronic components. We specialize in providing state-of-the-art technology and solutions that excel in the harsh operating conditions of the mobile off-highway market. Building on our extensive applications expertise, we work closely with our customers to ensure exceptional performance for a broad range of off-highway vehicles.

We help OEMs around the world speed up system development, reduce costs and bring vehicles to market faster.

Danfoss – Your Strongest Partner in Mobile Hydraulics.

Go to www.powersolutions.danfoss.com for further product information.

Wherever off-highway vehicles are at work, so is Danfoss.

We offer expert worldwide support for our customers, ensuring the best possible solutions for outstanding performance. And with an extensive network of Global Service Partners, we also provide comprehensive global service for all of our components.

Please contact the Danfoss Power Solution representative nearest you.

Comatrol

www.comatrol.com

Schwarzmueller-Inverter

www.schwarzmueller-inverter.com

Turolla

www.turollaocg.com

Valmova

www.valmova.com

Hydro-Gear

www.hydro-gear.com

Daikin-Sauer-Danfoss

www.daikin-sauer-danfoss.com

Local address:

Danfoss Power Solutions (US) Company
2800 East 13th Street
Ames, IA 50010, USA
Phone: +1 515 239 6000

Danfoss Power Solutions GmbH & Co. OHG
Krokamp 35
D-24539 Neumünster, Germany
Phone: +49 4321 871 0

Danfoss Power Solutions ApS
Nordborgvej 81
DK-6430 Nordborg, Denmark
Phone: +45 7488 2222

Danfoss Power Solutions Trading (Shanghai) Co., Ltd.
Building #22, No. 1000 Jin Hai Rd
Jin Qiao, Pudong New District
Shanghai, China 201206
Phone: +86 21 3418 5200

Danfoss can accept no responsibility for possible errors in catalogues, brochures and other printed material. Danfoss reserves the right to alter its products without notice. This also applies to products already on order provided that such alterations can be made without changes being necessary in specifications already agreed. All trademarks in this material are property of the respective companies. Danfoss and the Danfoss logotype are trademarks of Danfoss A/S. All rights reserved.